



 **LORENZOLINE**

150BC

Bioclimatic System

150BC

BIOCLIMATIC SYSTEM BIOKLİMATİK SİSTEM



- Provides natural light thanks to aluminium and glass lamellas combination.
- Quicker installation thanks to practical connection accessories.
- More durability thanks to reinforced lamella covers.
- Longer life thanks to stainless steel fasteners.
- Bioclimatic and Rolling Roofs can be built with the same profiles.
- Special gutter solutions for water sealing.

- Alüminyum lamel ve cam lamel kombinasyonu ile doğal ışık imkanı,
- Pratik birleşim aksesuarları sayesinde daha hızlı montaj imkanı.
- Güçlendirilmiş lamel kapakları sayesinde daha sağlam,
- Paslanmaz bağlantı elemanlarıyla sayesinde daha uzun ömürlü,
- Aynı profillerle Bioclimatic ve Rolling Roof yapabilme,
- Su sızdırmazlık için özel oluk çözümleri,



PROFILES
PROFILLER

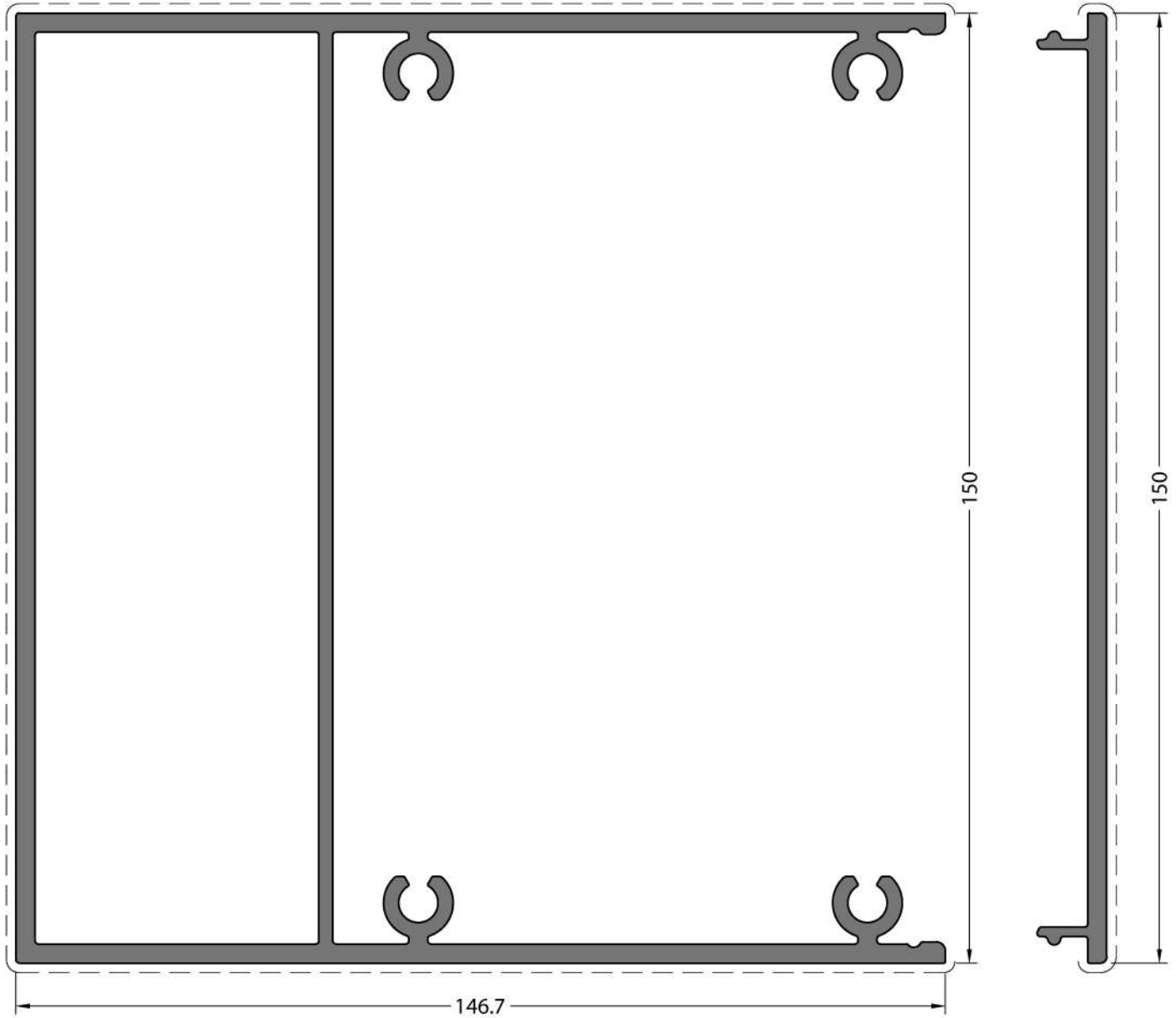

CODE / KOD

150BC-101-00

THEORETICAL WEIGHT
TEORİK AĞIRLIK (kg/m)

5.108

CODE / KOD

150BC-102-00

THEORETICAL WEIGHT
TEORİK AĞIRLIK (kg/m)

1.291

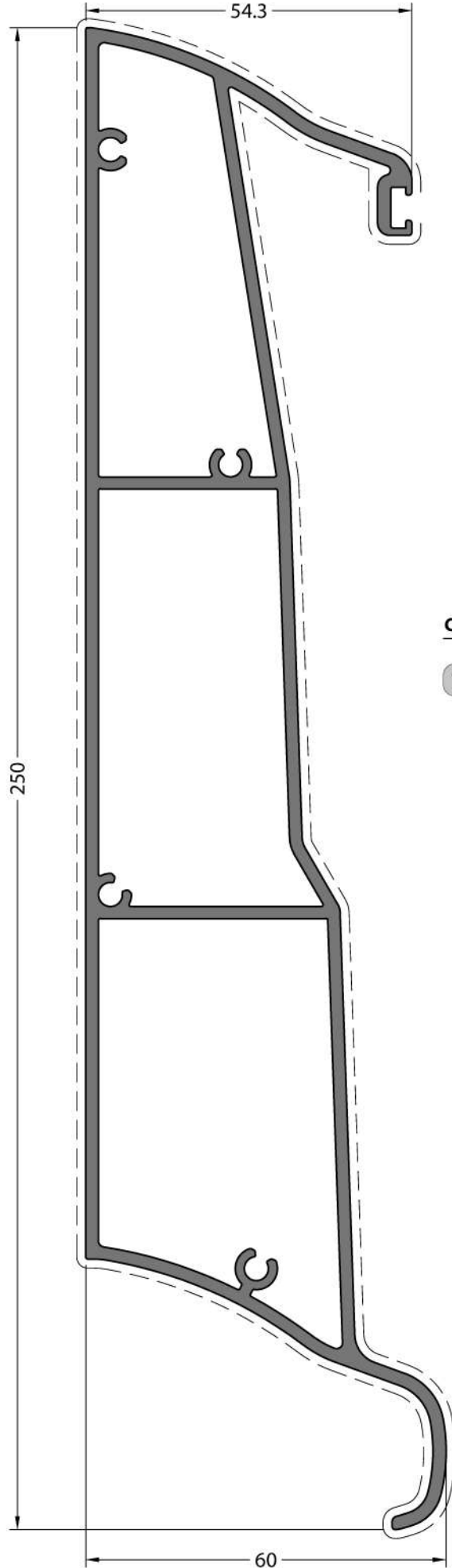

CODE / KOD

150BC-201-00

THEORETICAL WEIGHT

TEORİK AĞIRLIK (kg/m)

3.850

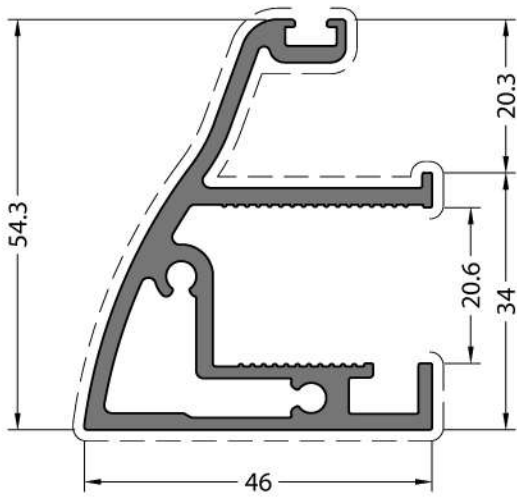

CODE / KOD
150BC-211-00

THEORETICAL WEIGHT
TEORİK AĞIRLIK (kg/m)
1.247

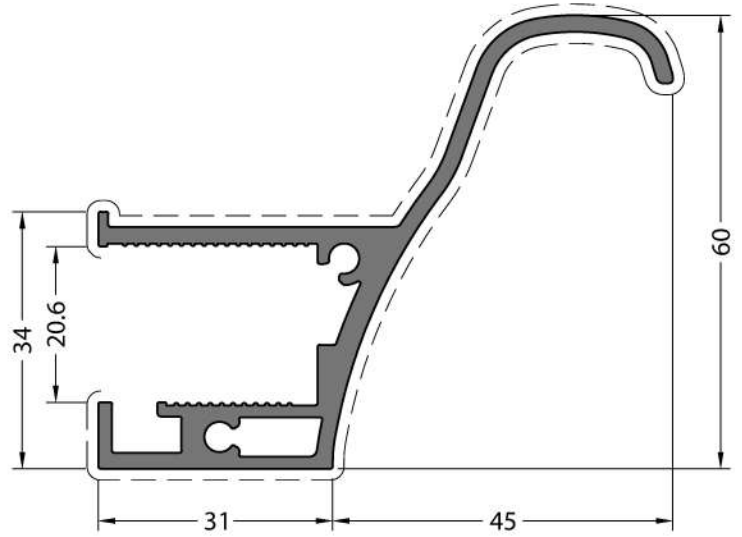

CODE / KOD
150BC-212-00

THEORETICAL WEIGHT
TEORİK AĞIRLIK (kg/m)
1.233

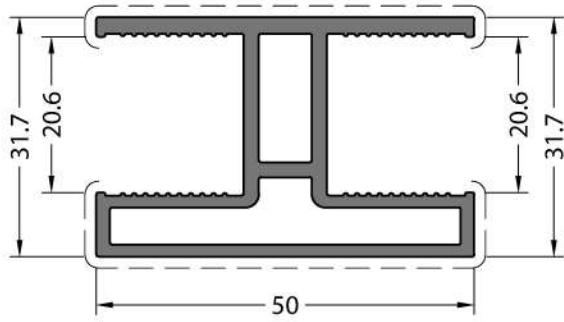

CODE / KOD
150BC-213-00

THEORETICAL WEIGHT
TEORİK AĞIRLIK (kg/m)
1.032

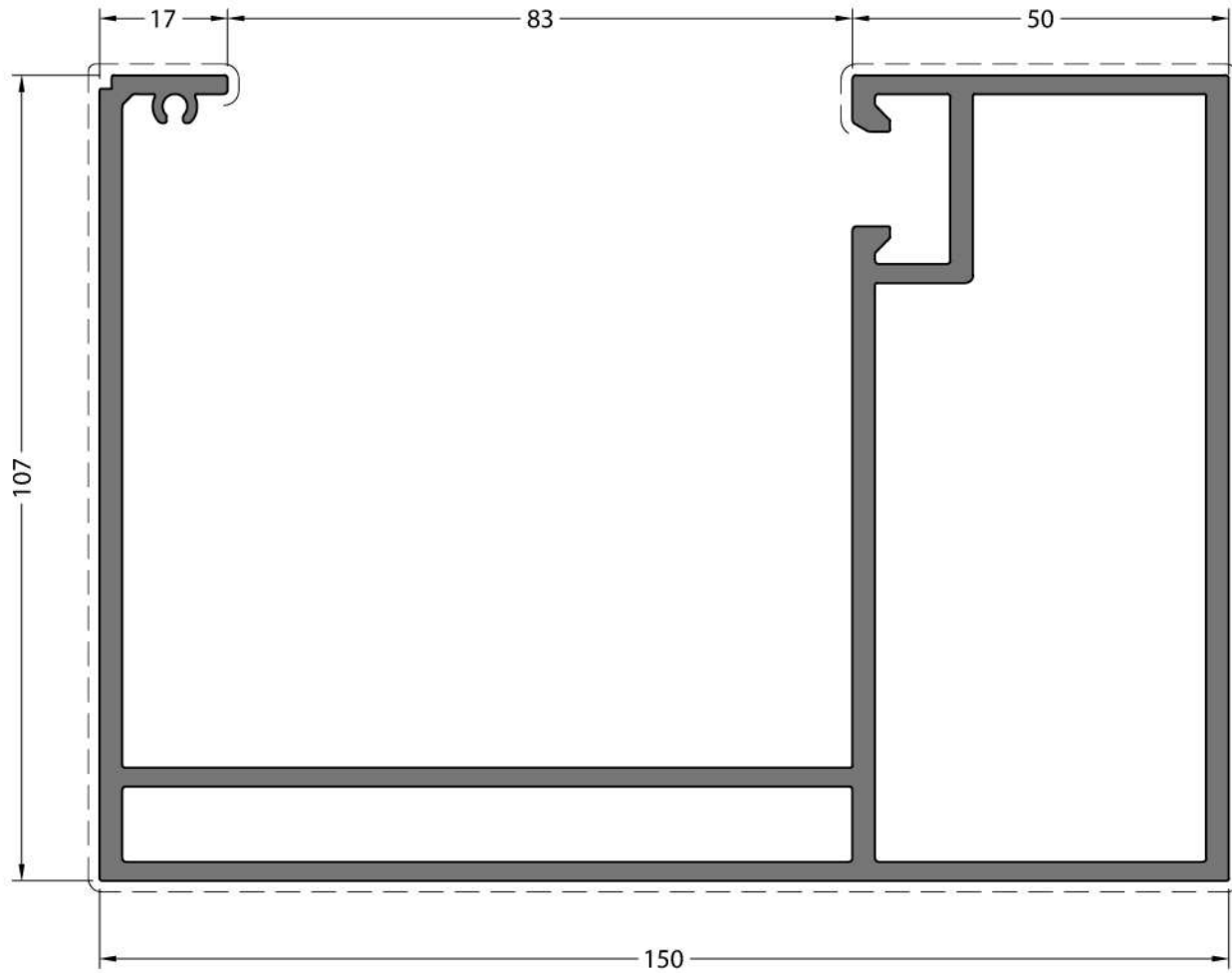

CODE / KOD

150BC-301-00

THEORETICAL WEIGHT

TEORİK AĞIRLIK (kg/m)

4.815



CODE / KOD

150BC-302-00

THEORETICAL WEIGHT

TEORİK AĞIRLIK (kg/m)

1.299

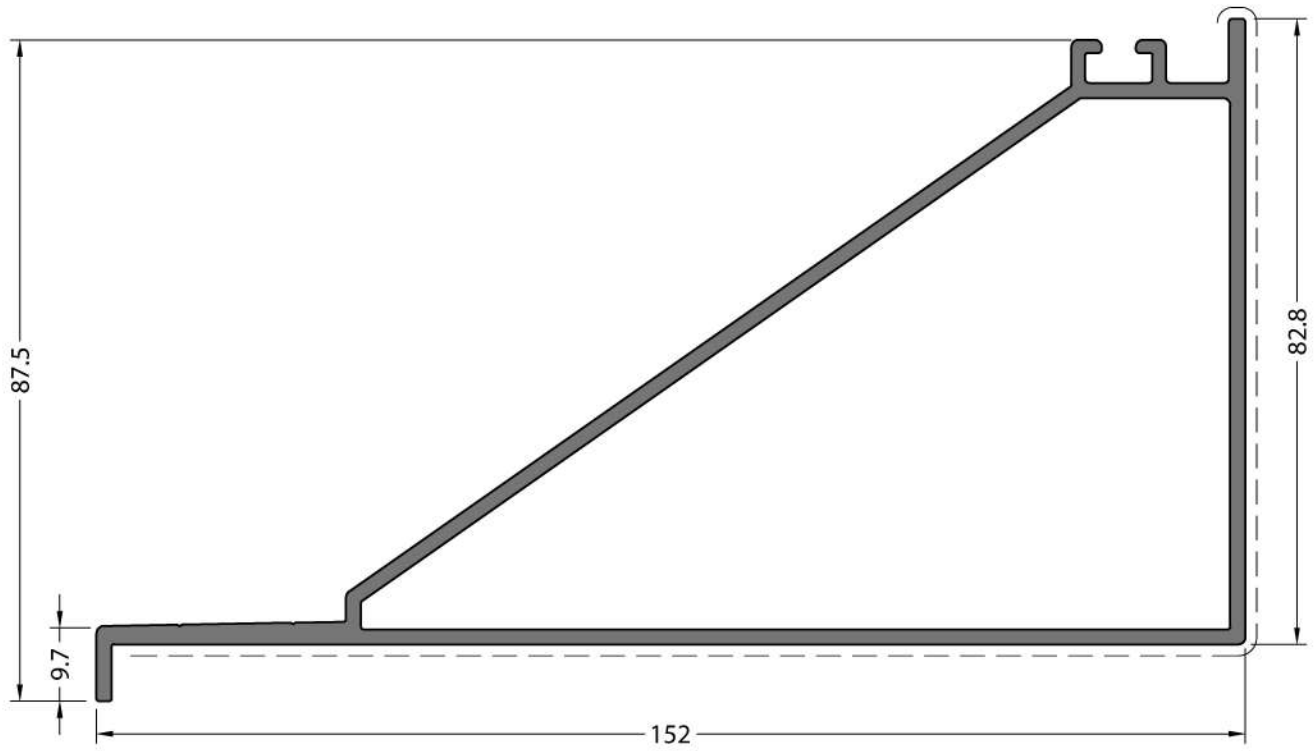

CODE / KOD

150BC-303-00

THEORETICAL WEIGHT

TEORİK AĞIRLIK (kg/m)

2.203

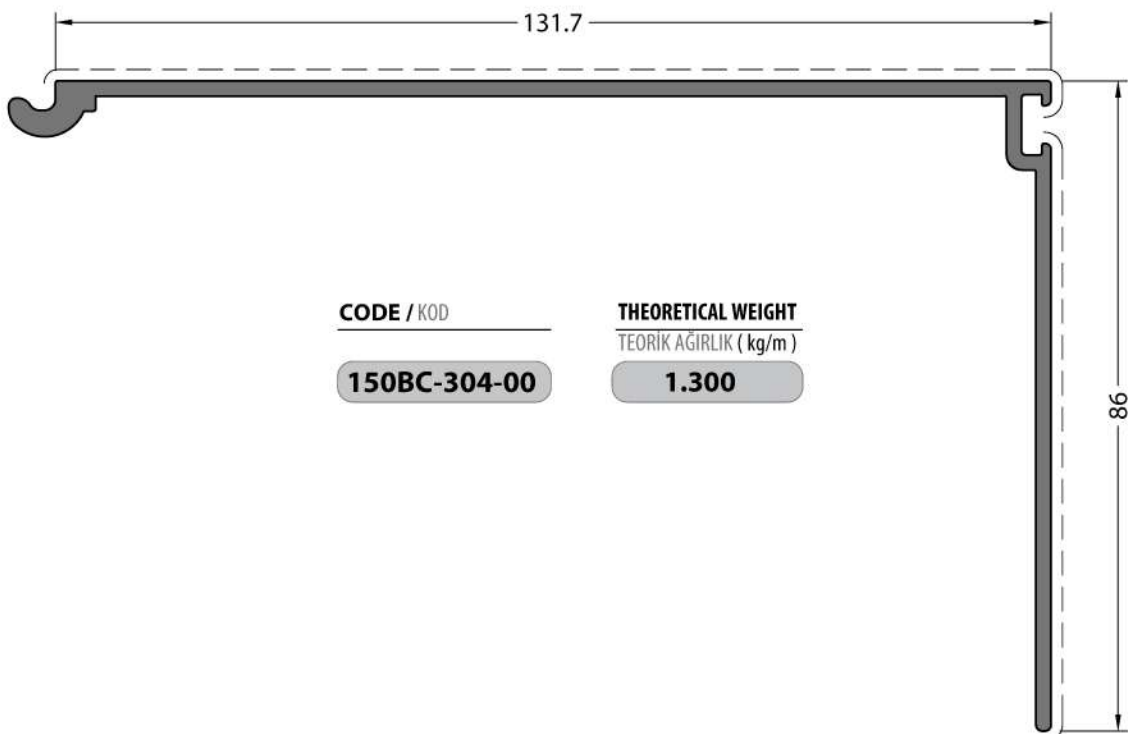

CODE / KOD

150BC-304-00

THEORETICAL WEIGHT

TEORİK AĞIRLIK (kg/m)

1.300

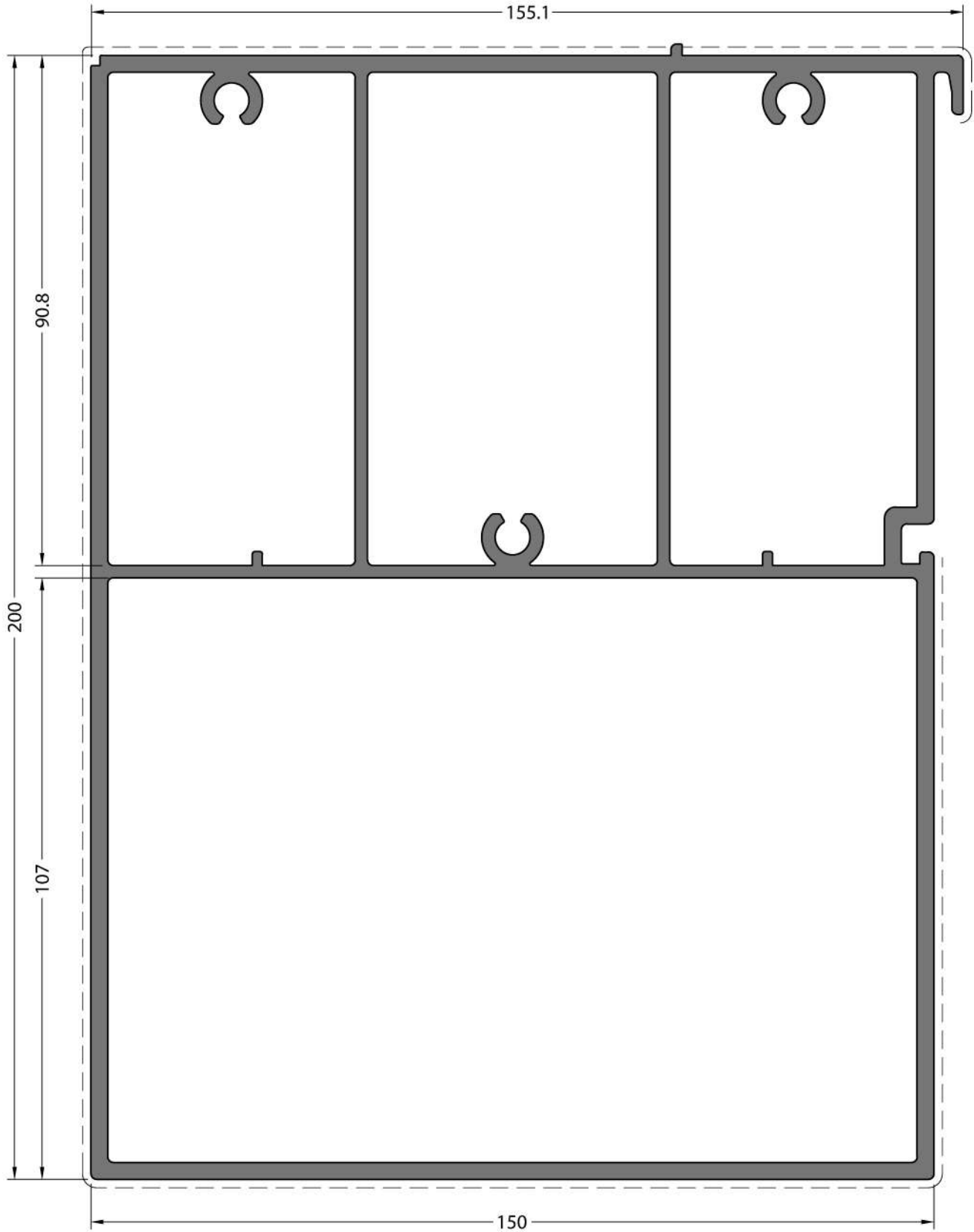

CODE / KOD

150BC-401-00

THEORETICAL WEIGHT

TEORİK AĞIRLIK (kg/m)

8.080

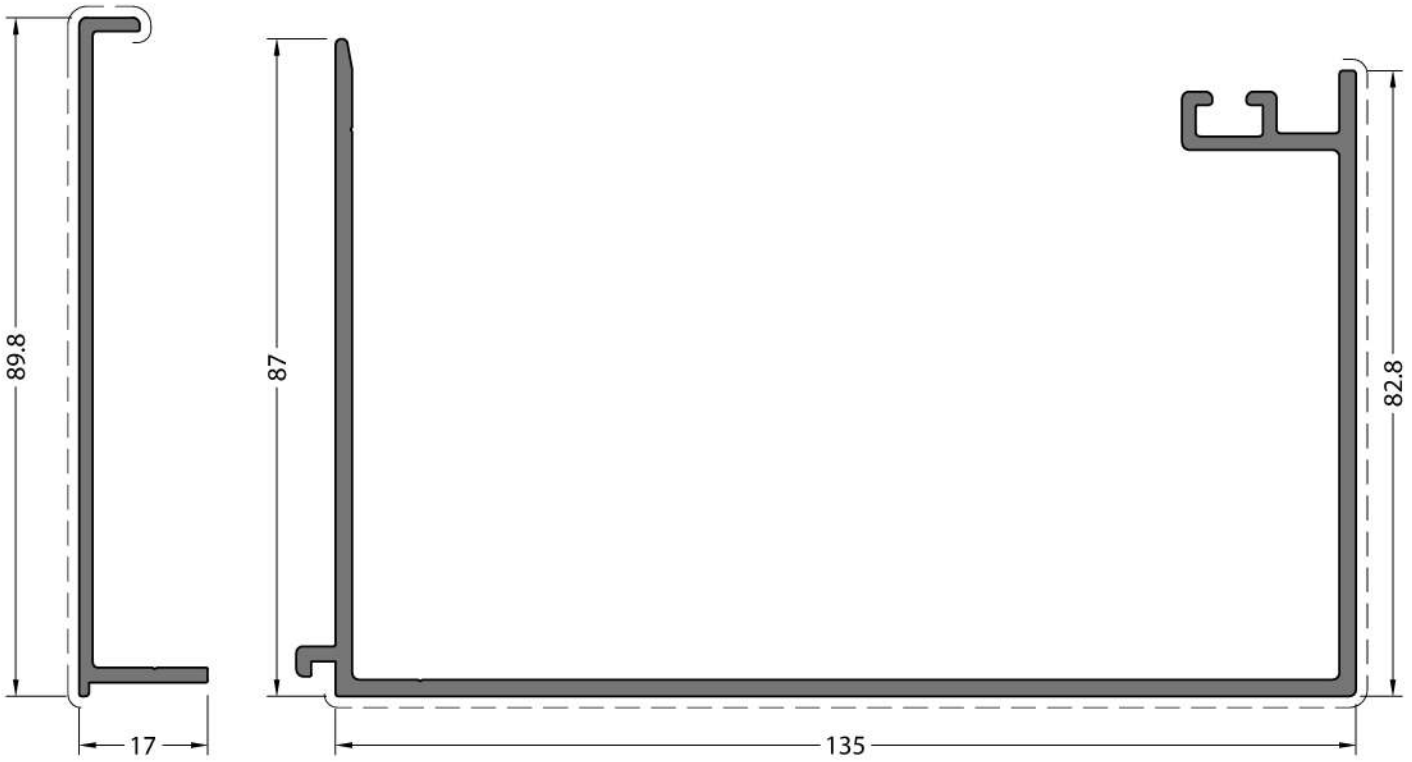

CODE / KOD

150BC-402-00

THEORETICAL WEIGHT
TEORİK AĞIRLIK (kg/m)

1.291

CODE / KOD

150BC-403-00

THEORETICAL WEIGHT
TEORİK AĞIRLIK (kg/m)

2.004

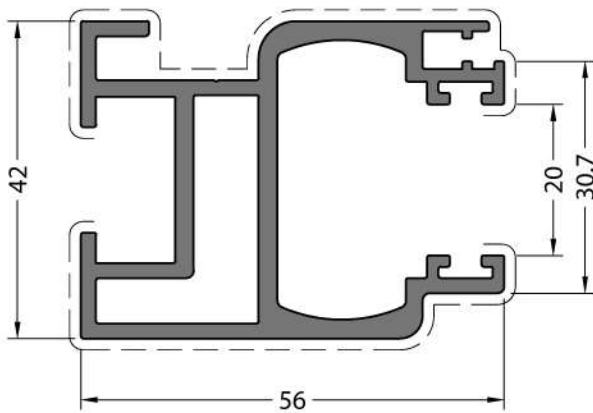

CODE / KOD

150BC-501-00

THEORETICAL WEIGHT
TEORİK AĞIRLIK (kg/m)

1.507

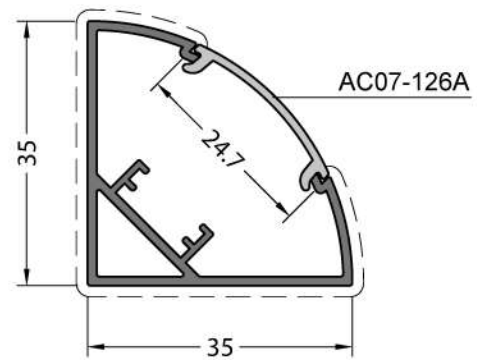

CODE / KOD

07-126-00

THEORETICAL WEIGHT
TEORİK AĞIRLIK (kg/m)

0.419

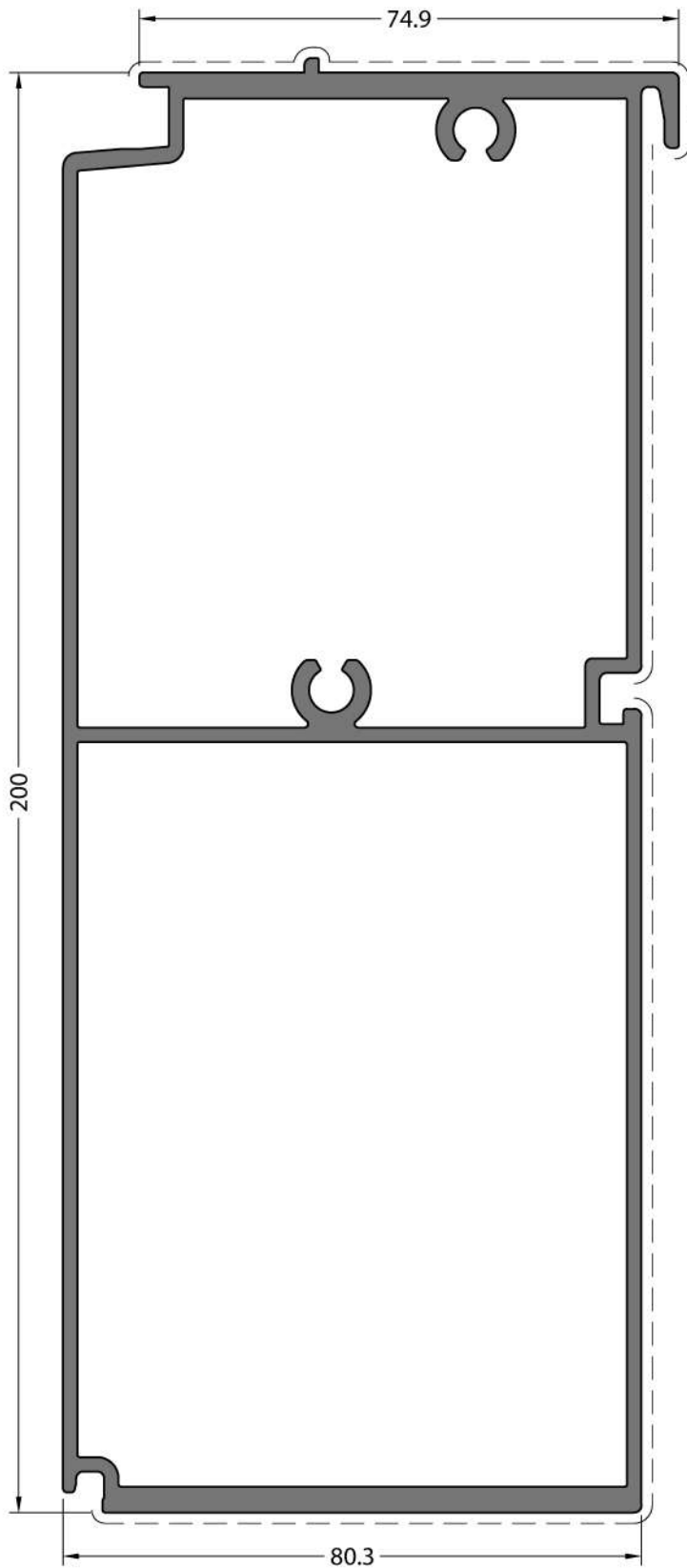

CODE / KOD

150BC-411-00

THEORETICAL WEIGHT
TEORİK AĞIRLIK (kg/m)

4.425

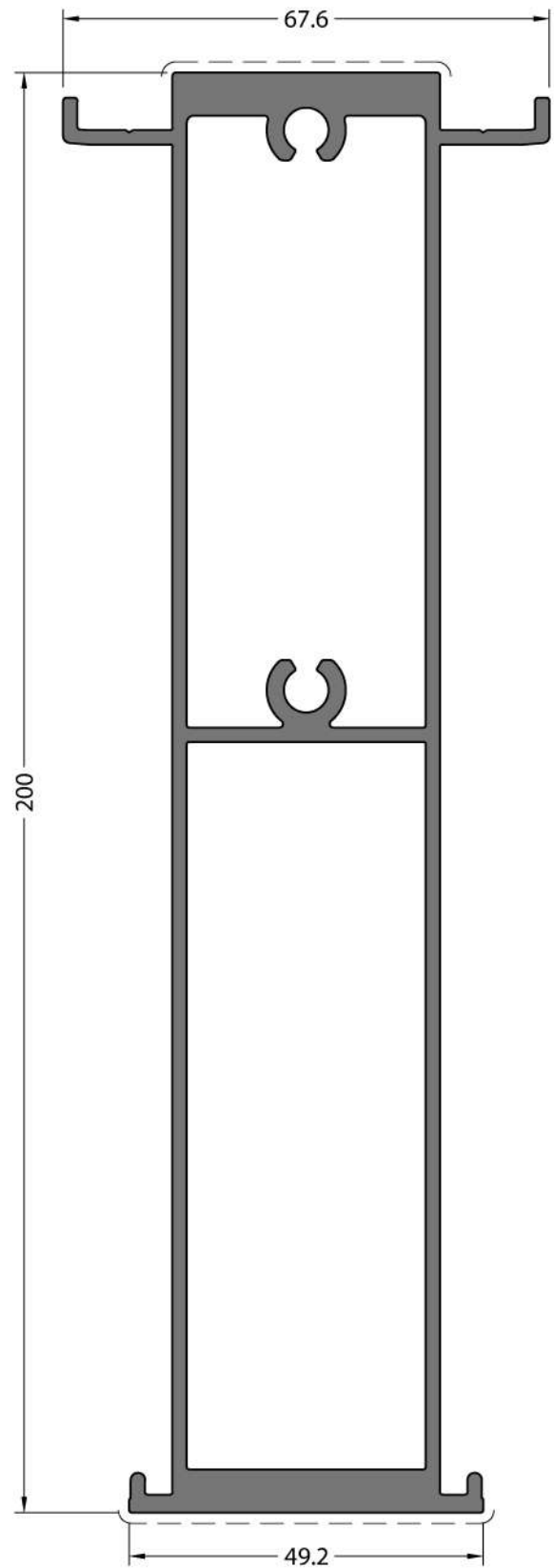

CODE / KOD

150BC-413-00

THEORETICAL WEIGHT
TEORİK AĞIRLIK (kg/m)

3.957

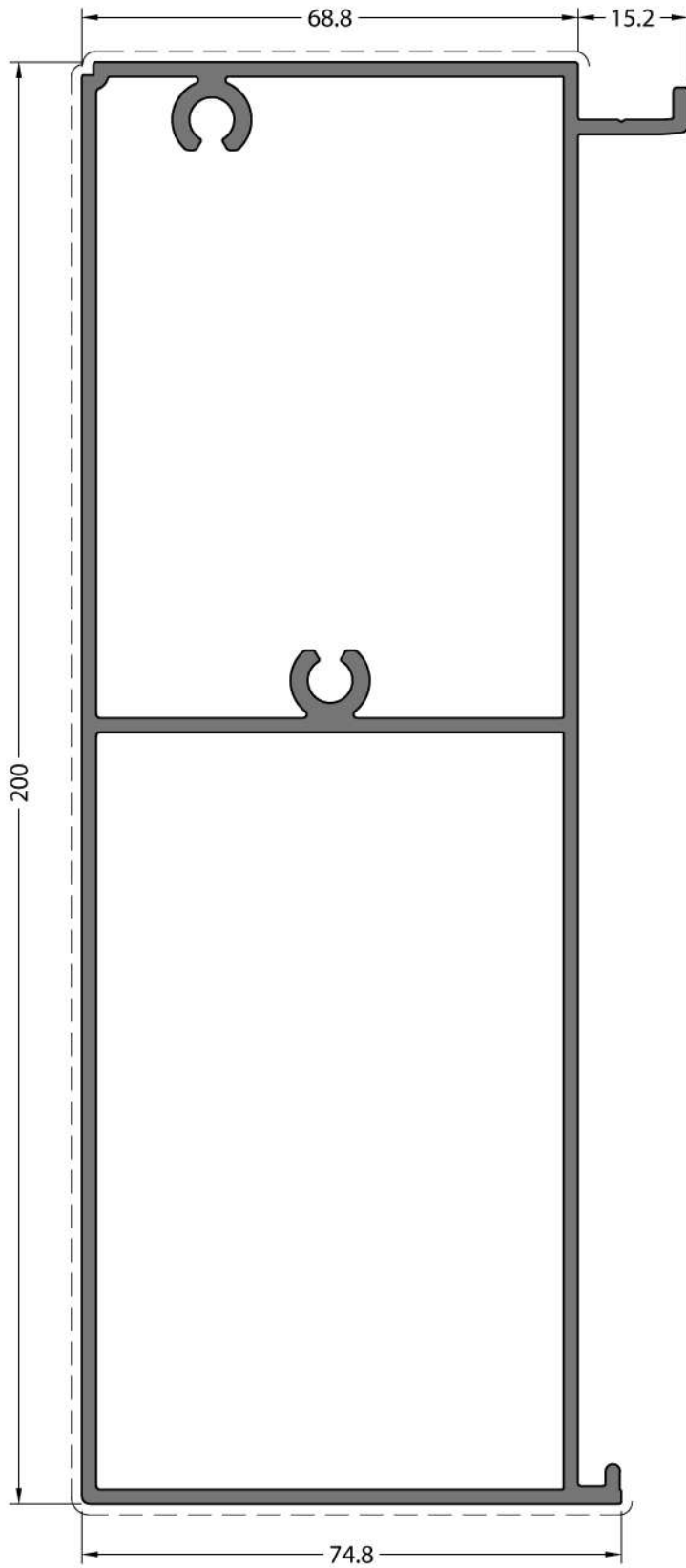

CODE / KOD

150BC-412-00

THEORETICAL WEIGHT
TEORİK AĞIRLIK (kg/m)

3.666

DETAILS
DETAYLAR

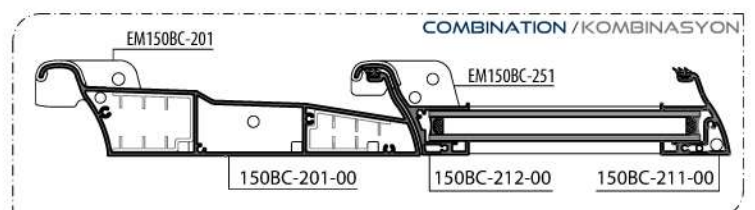
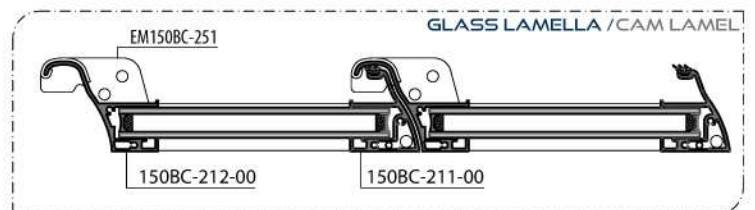
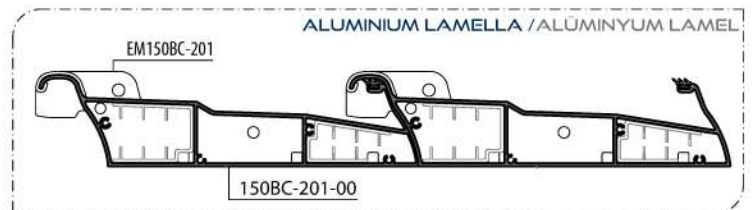
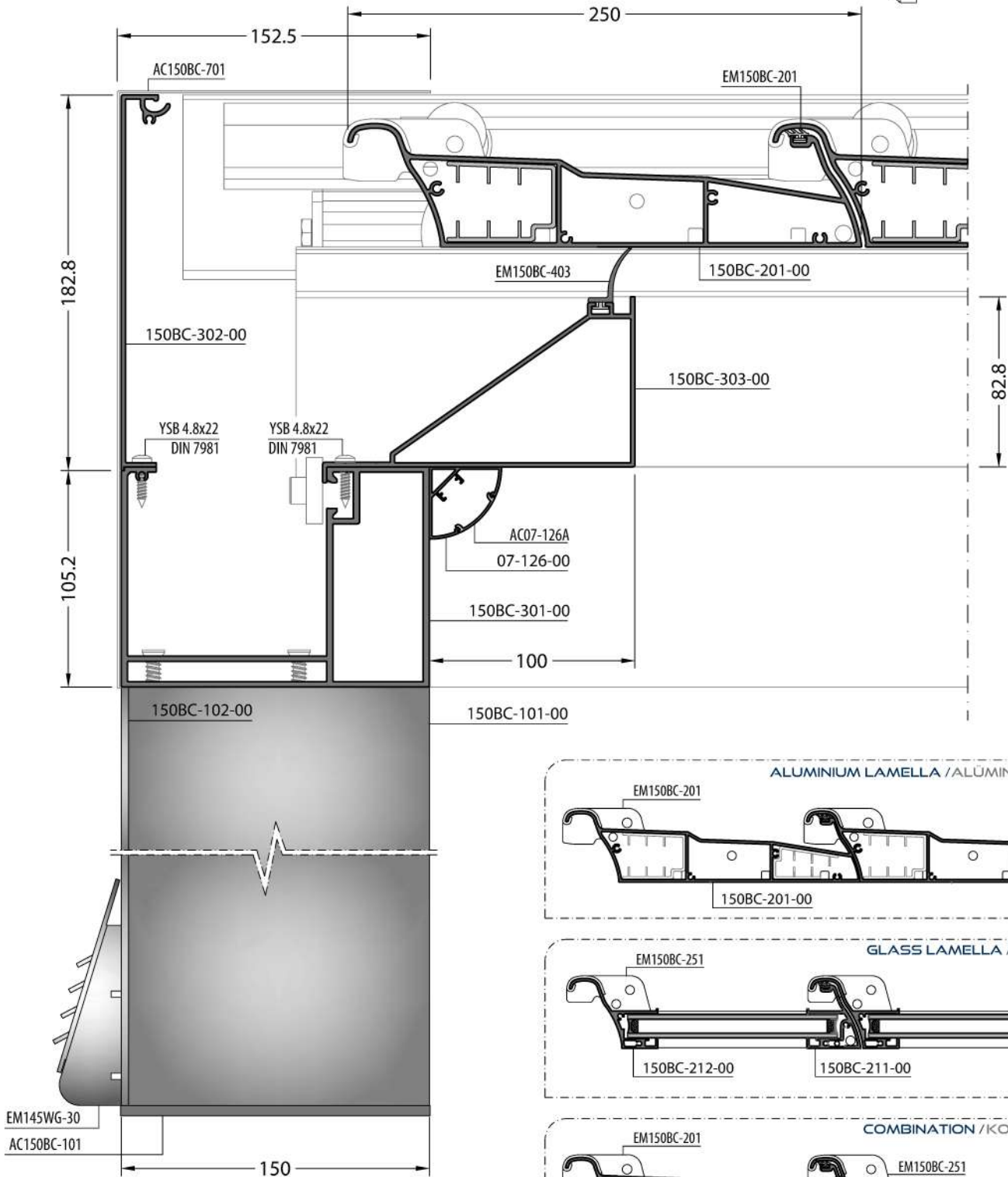
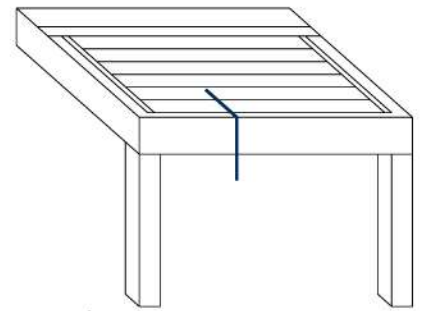

No scaled / Ölçeksiz

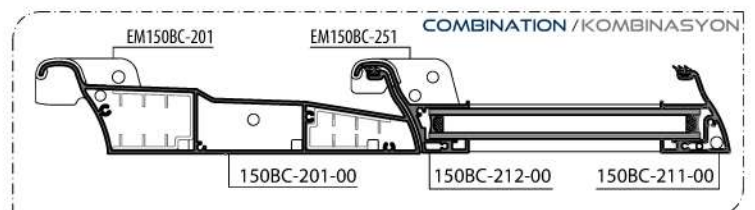
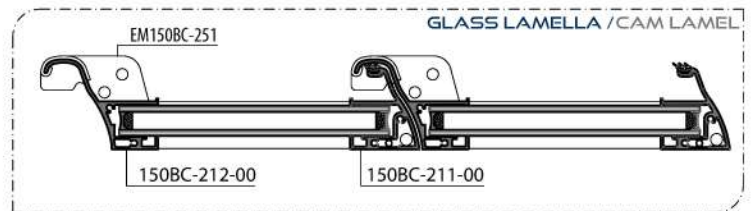
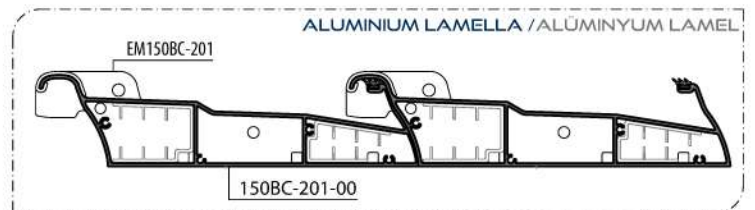
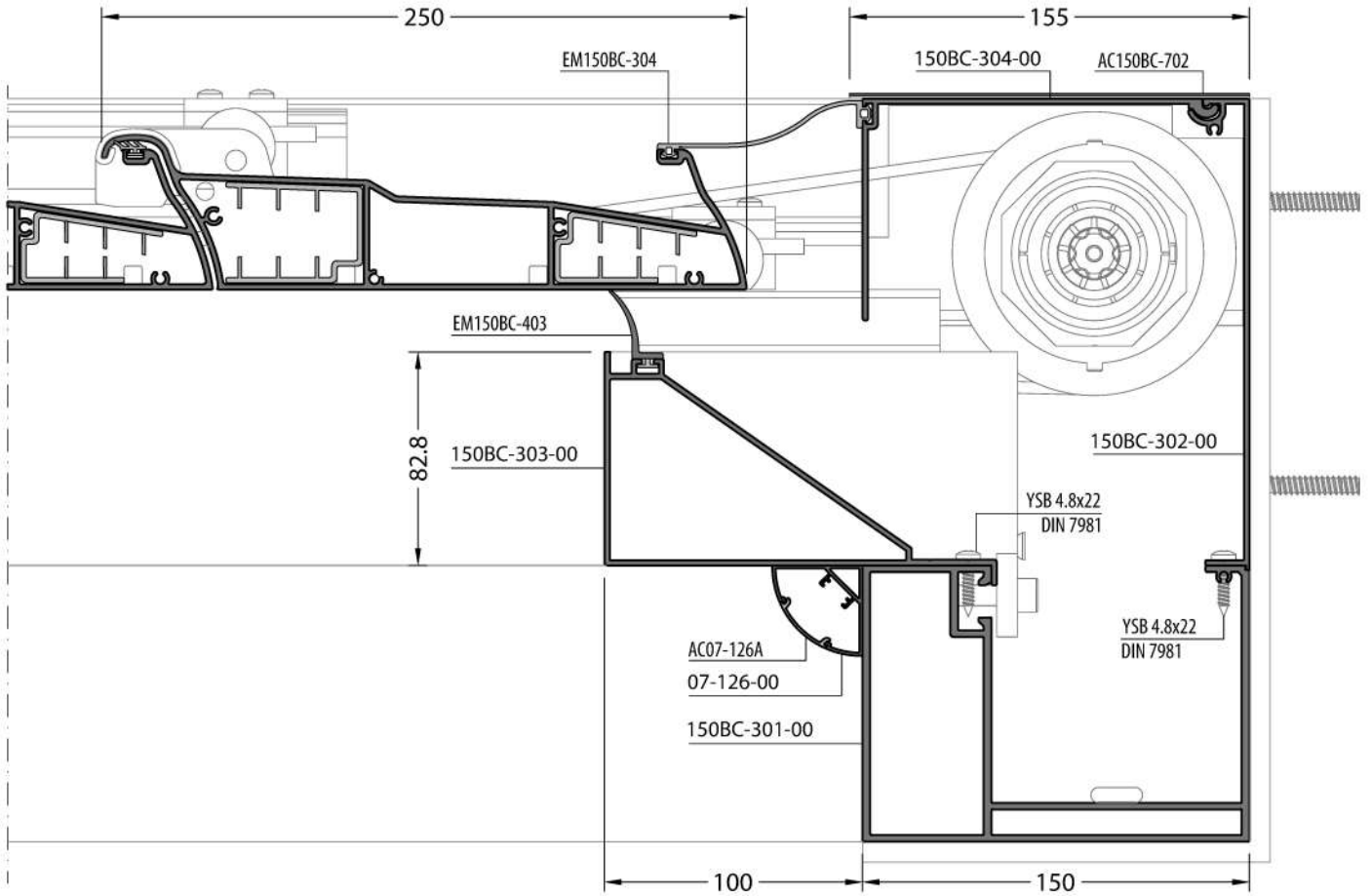
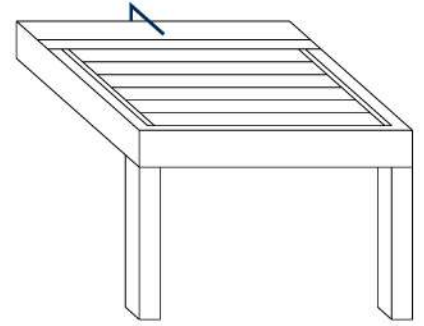

No scaled / Ölçeksiz

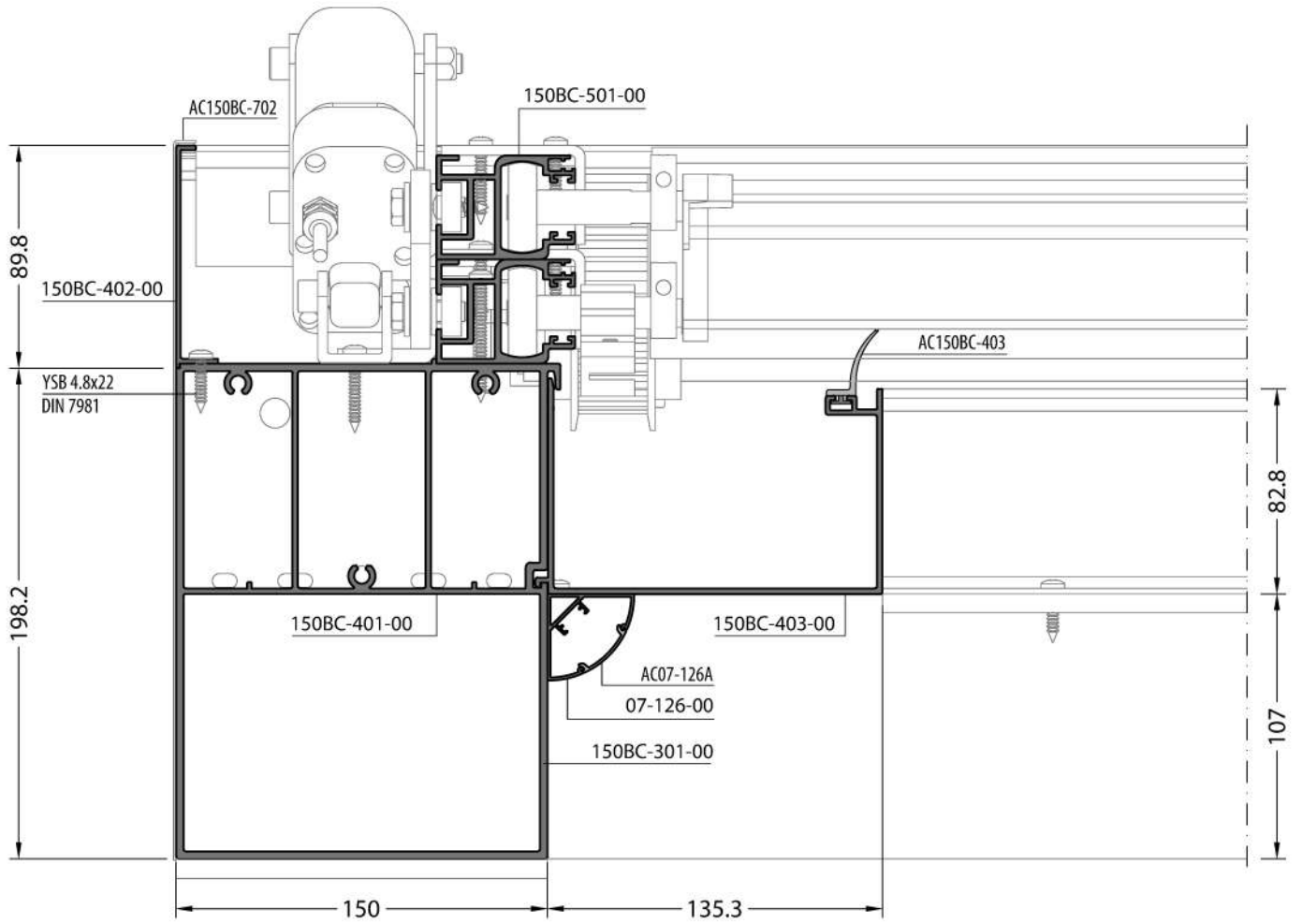
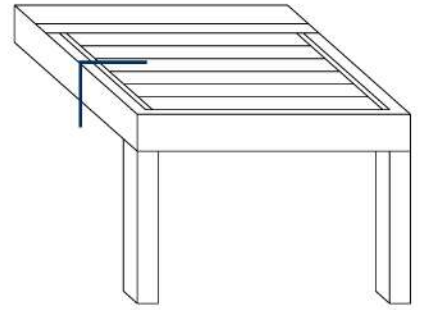

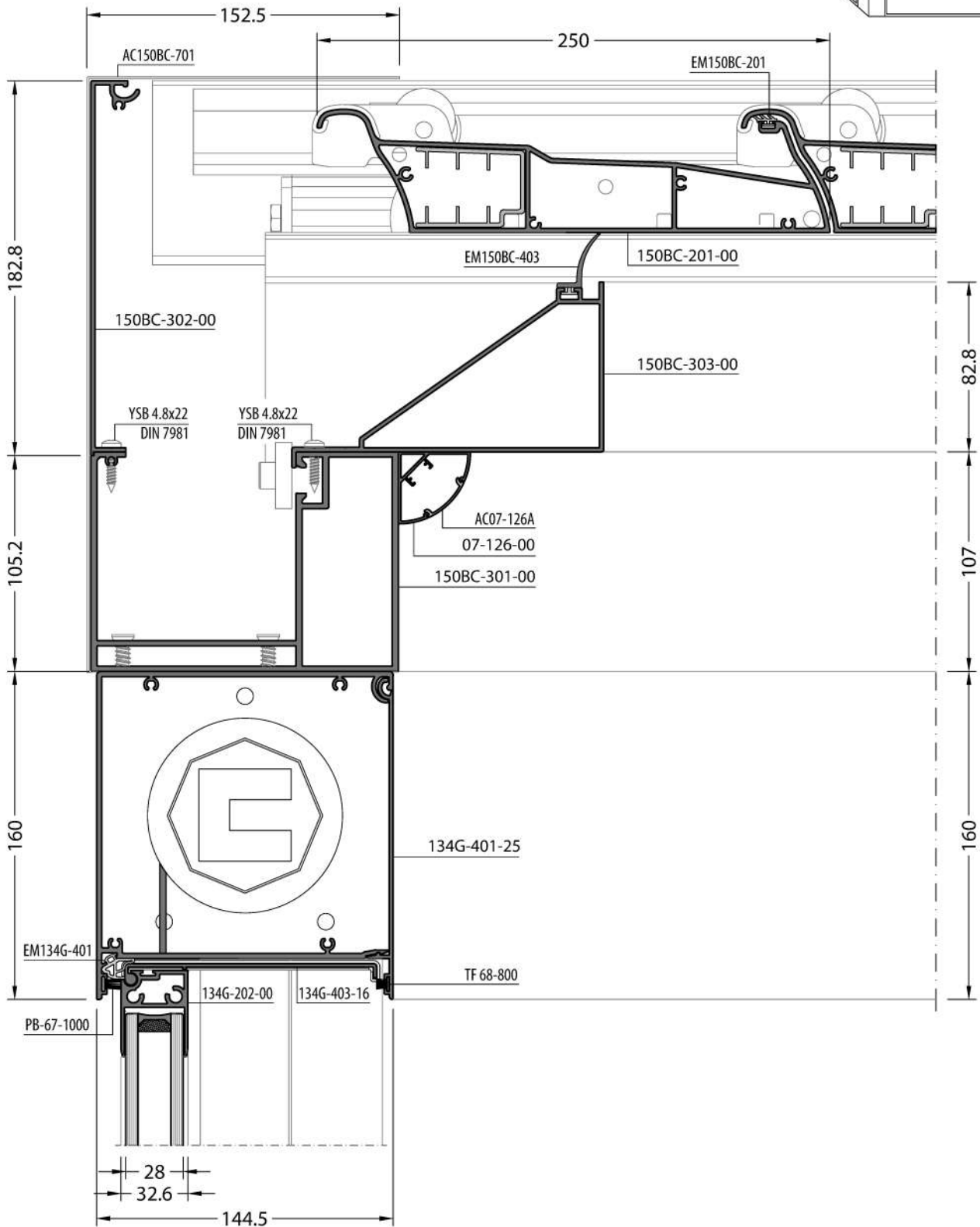
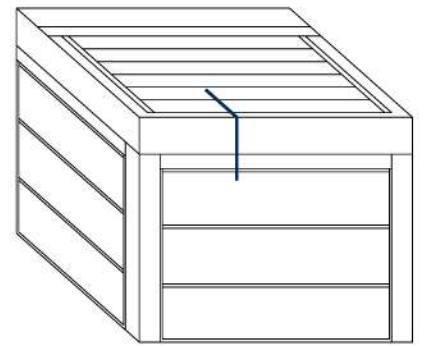

No scaled / Ölçeksiz

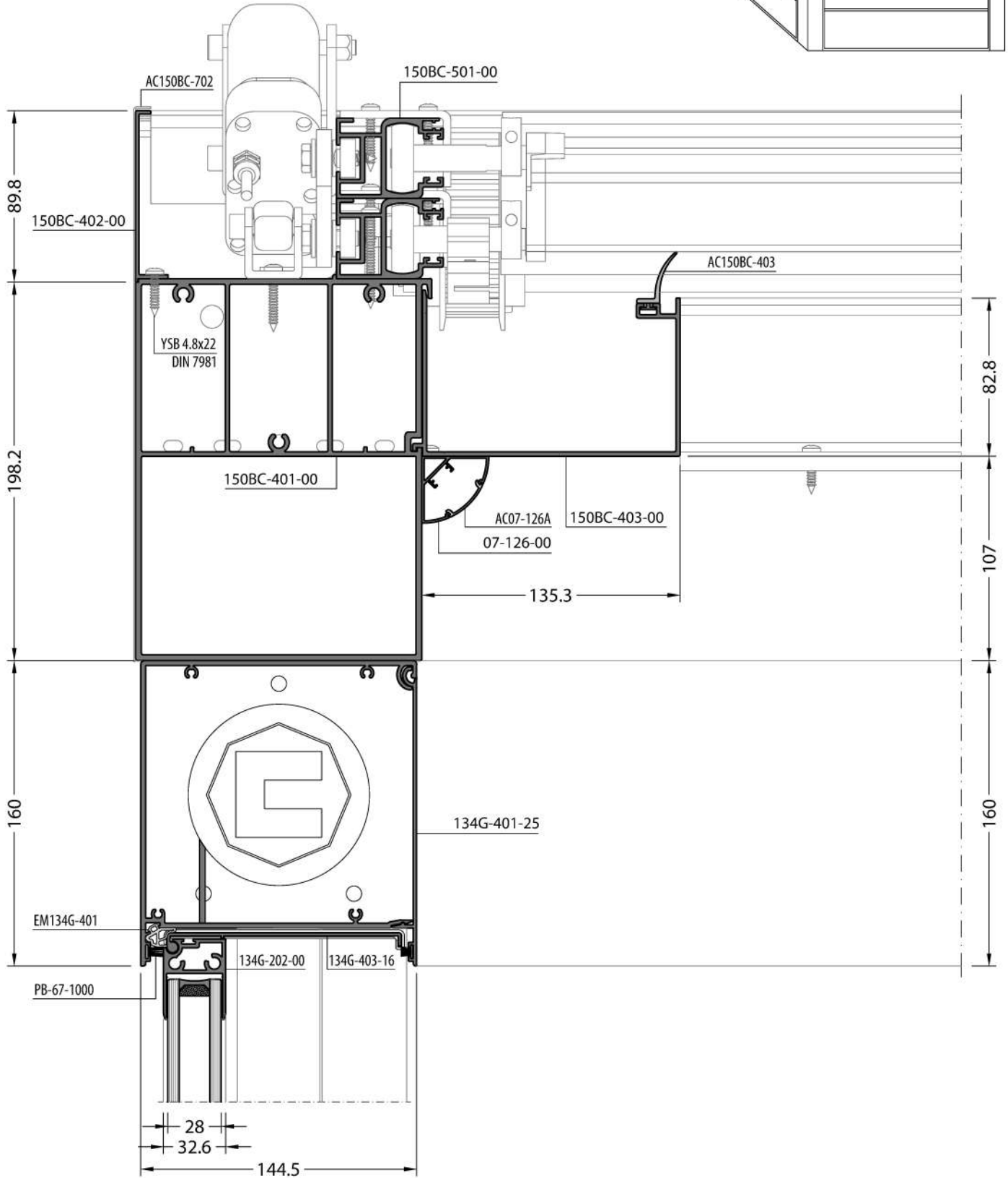
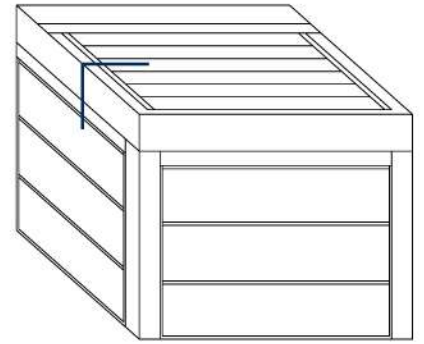

No scaled / Ölçeksiz

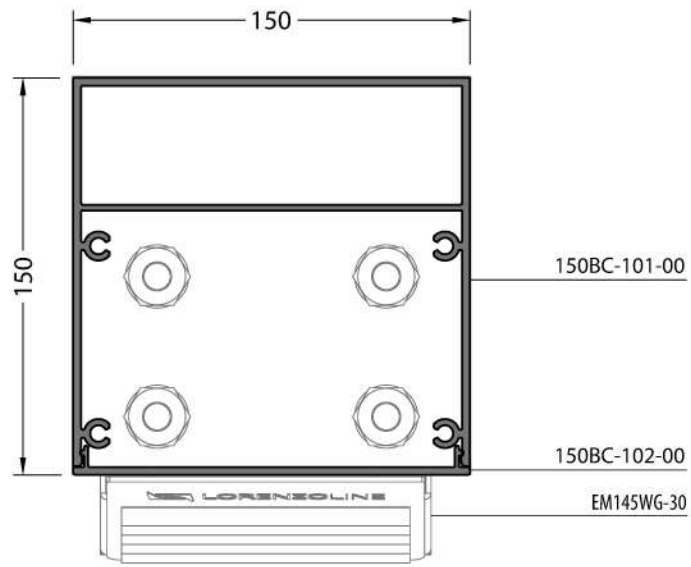
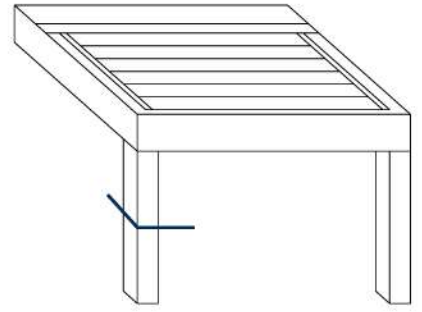

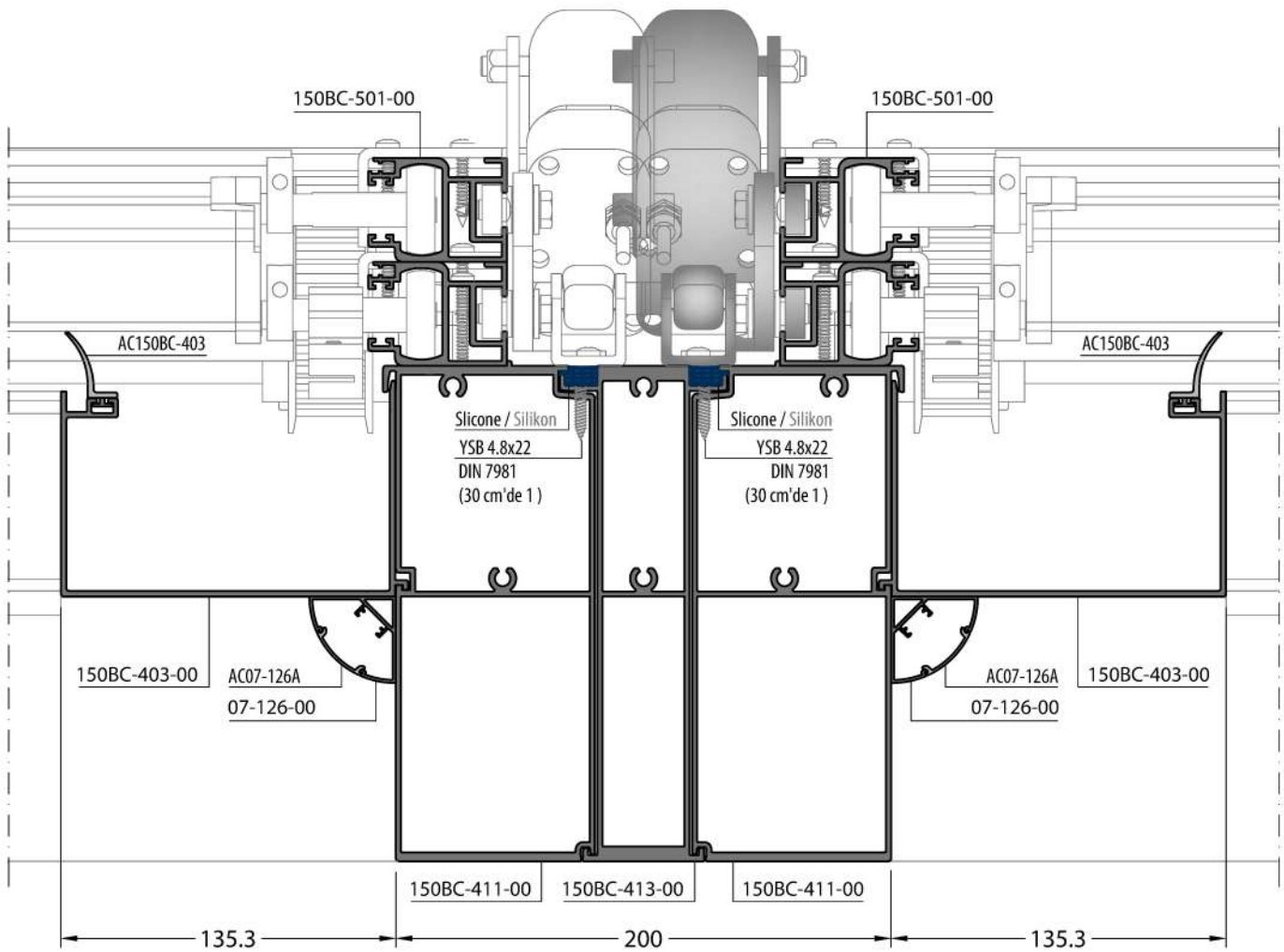
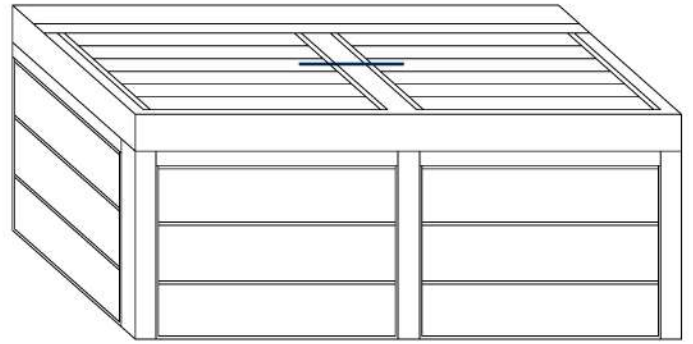

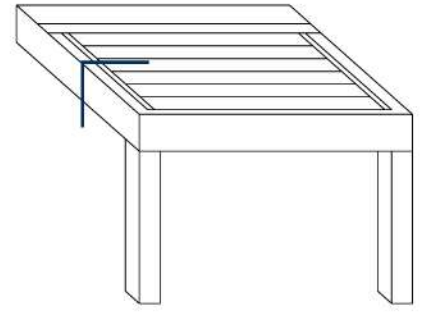



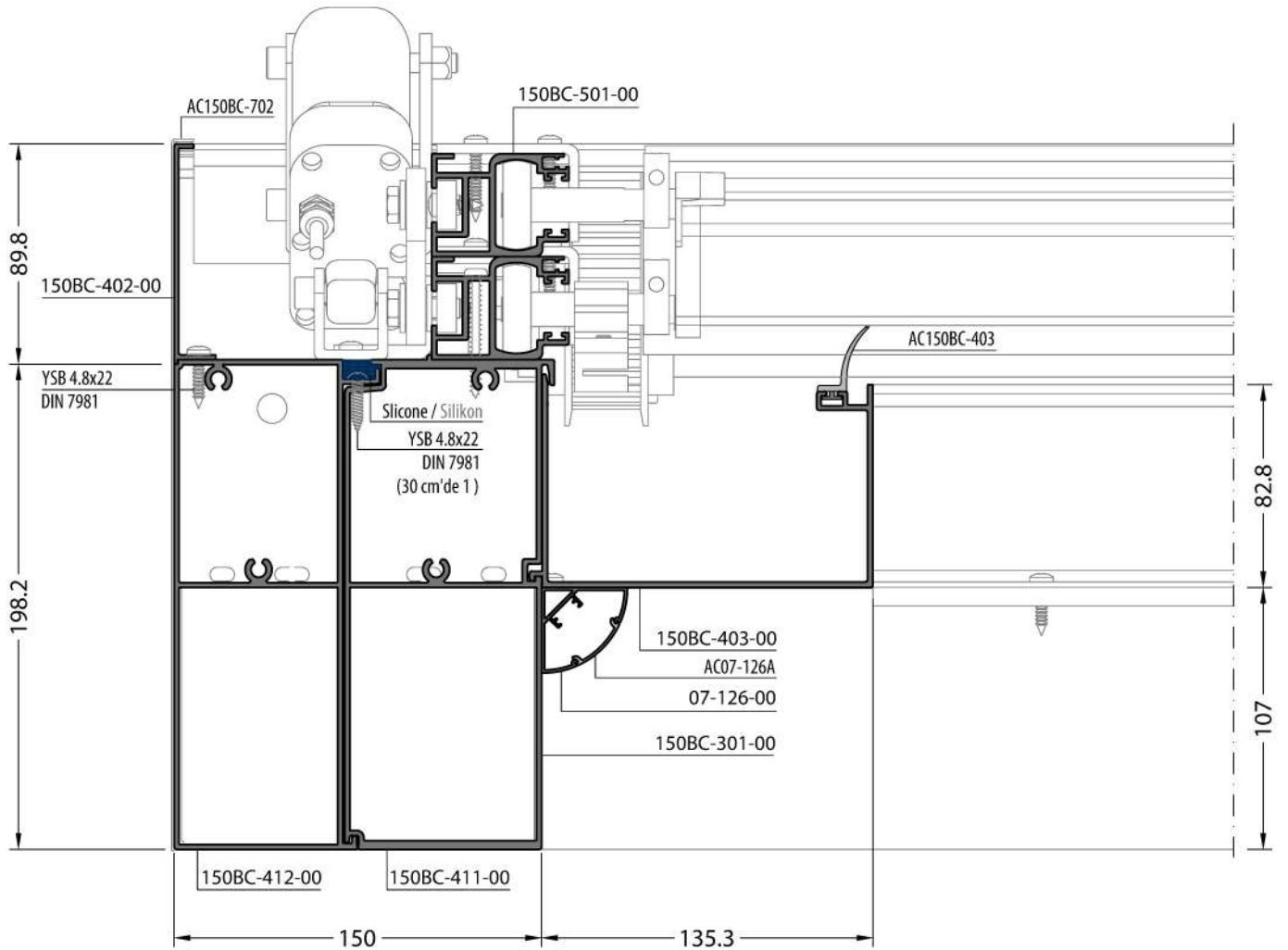







150BC-401-00
ALTERNATIVE PROFILE
PROFİLİN ALTERNATİFİ



















ACCESSORIES
AKSESUARLAR









**BIOCLIMATIC
ACCESSORIES / AKSESUARLAR**

PACKAGE CODE PAKET KODU	PICTURE / RESİM	DESCRIPTION AÇIKLAMA	PACKAGE CODE PAKET KODU	PICTURE / RESİM	DESCRIPTION AÇIKLAMA
AC150BC-201		LAMELLA CAP SIDE SET LAMEL YAN KAPAK TAKIMI	AC150BC-502		TRIGGER TENSION SET TRIGER GERGİ TAKIMI
AC150BC-251		GLASS LAMELLA CAP SIDE SET CAM LAMEL YAN KAPAK TAKIMI	AC150BC-550		LAMELLA LOCK SET LAMEL KİTLEME BRAKETİ
AC150BC-202		PULLEY RULMAN	AC150BC-611		MIDDLE STEEL BRACKET ORTA ÇELİK BRAKET
AC150BC-221		FRICTION HINGE BIOCLIMATIC MAKAS BİOKLİMATİK	AC150BC-261		LAMELLA SUPPORT WEDGE LAMEL DESTEK TAKOZU
AC150BC-401		MAIN RAIL BRACKET ANA RAY MONTAJ PLAKASI	AC150BC-510		TRIGGER CONNECTION PART TRIGER BİRLEŞİM ELEMANI
AC150BC-411		ALTERNATIVE MAIN RAIL BRACKET ALTERNATİF ANA RAY MONTAJ PLAKASI	AC150BC-231		ROPE RING HALAT YÜZÜĞÜ
AC150BC-402		SPECIAL MAIN RAIL BRACKET FOR TWO MODULUS İKİ MODÜL İÇİN ÖZEL ANA RAY MONTAJ PLAKASI	AC150BC-232		COATED STAINLESS ROPE KAPALAMALI PASLANMAZ HALAT
AC150BC-101		POST BRACKET KOLON ANKRAJİ	AC150BC-233		ALUMINUM WASHER ALÜMİNYUM PUL







**BIOCLIMATIC
ACCESSORIES / AKSESUARLAR**

PACKAGE CODE PAKET KODU	PICTURE / RESİM	DESCRIPTION AÇIKLAMA	PACKAGE CODE PAKET KODU	PICTURE / RESİM	DESCRIPTION AÇIKLAMA
AC150BC-570		WALL BRACKET DUVAR ANKRAJI	AC150BC-580		TUBULAR MOTOR BRACKET TÜP MOTOR ANKRAJ
AC150BC-602		80x160x6mm STEEL PROFILE ÇELİK PROFİL	AC150BC-583		OCTAGONAL TUBE SEKİZGEN BORU
AC150BC-501-40		BRUSH FİRÇA	AC150BC-305		OCTAGONAL PIPE SUPPORT ITEM SEKİZGEN BORU DESTEK ELEMANI
AC07-126A		LED PROFILE DIFFUSER LED PROFİL DİFÜZÖRÜ	AC150BC-582		TUBULAR MOTOR WITHOUT RECIEVER ALICILI TÜP MOTOR
AC07-126B		LED PROFILE CORNER LED PROFİL KÖŞE ELEMANI	AC150BC-584		TUBE HEAD BORU BAŞI
EM145WG-20/D		GUTTER FILTER OLUK SÜZGEÇİ	AC150BC-584		MOTOR TRIGER GEAR MOTOR TRIGER DİŞLİSİ
EM145WG-30		POST DRAINAGE CAP KOLON TAHLİYE KAPAĞI	AC150BC-500		TRIGER BELT TRIGER KAYIŞ T10
AC150BC-301		HOLE TEMPLATE DELİK ŞABLONU (150BC-301-00)	AC150BC-591		CONTROL PANEL KONTROL ÜNİTESİ

**BIOCLIMATIC
ACCESSORIES / AKSESUARLAR**

PACKAGE CODE PAKET KODU	PICTURE / RESİM	DESCRIPTION AÇIKLAMA
AC150BC-592		REMOTE CONTROL KUMANDA
AC150BC-593		INSULATED LED (Daylight) İZOLELİ LED (Gün Işığı)
AC150BC-594		LED TRANSFORMER LED TRAFOSU
AC150BC-562		LINEER MOTOR BRACKET SET LİNEER MOTOR BRAKET TAKIMI
AC150BC-561		LINEER MOTOR LİNEER MOTOR
AC150BC-403		SMALL GUTTER SHEET KÜÇÜK OLUK LEVHA
AC150BC-701		CORNER COVER SHEET SET KÖŞE KAPAMA LEVHA
AC150BC-702		BACK COVER SHEET SET ARKA KAPAMA LEVHA

**BIOCLIMATIC
ACCESSORIES / AKSESUARLAR**

PACKAGE CODE PAKET KODU	PICTURE / RESİM	DESCRIPTION AÇIKLAMA
AC150BC-703		CENTER CONNECTION SHEET ORTA BİRLEŞİM LEVHA
EM150BC-201		LAMELLA GASKET LAMEL FİTİLİ
EM150BC-304		MOTOR LAMELLA GASKET MOTOR LAMEL FİTİLİ
EM150BC-403		ISOLATION GASKET İZOLASYON FİTİLİ
HM150BC-201-A		EPS EPS DOLGU Size / Ölçü 2 Meter / Metre
HM150BC-201-B		EPS EPS DOLGU Size / Ölçü 2 Meter / Metre
HM150BC-201-C		EPS EPS DOLGU Size / Ölçü 2 Meter / Metre

