



 **LORENZOLINE**

**150BC**

Bioclimatic System

# 150BC

## BIOCLIMATIC SYSTEM BIOKLİMATİK SİSTEM



- Provides natural light thanks to aluminium and glass lamellas combination.
- Quicker installation thanks to practical connection accessories.
- More durability thanks to reinforced lamella covers.
- Longer life thanks to stainless steel fasteners.
- Bioclimatic and Rolling Roofs can be built with the same profiles.
- Special gutter solutions for water sealing.

- Alüminyum lamel ve cam lamel kombinasyonu ile doğal ışık imkanı,
- Pratik birleşim aksesuarları sayesinde daha hızlı montaj imkanı.
- Güçlendirilmiş lamel kapakları sayesinde daha sağlam,
- Paslanmaz bağlantı elemanlarıyla sayesinde daha uzun ömürlü,
- Aynı profillerle Bioclimatic ve Rolling Roof yapabilme,
- Su sızdırmazlık için özel oluk çözümleri,



PROFILES  
PROFILLER

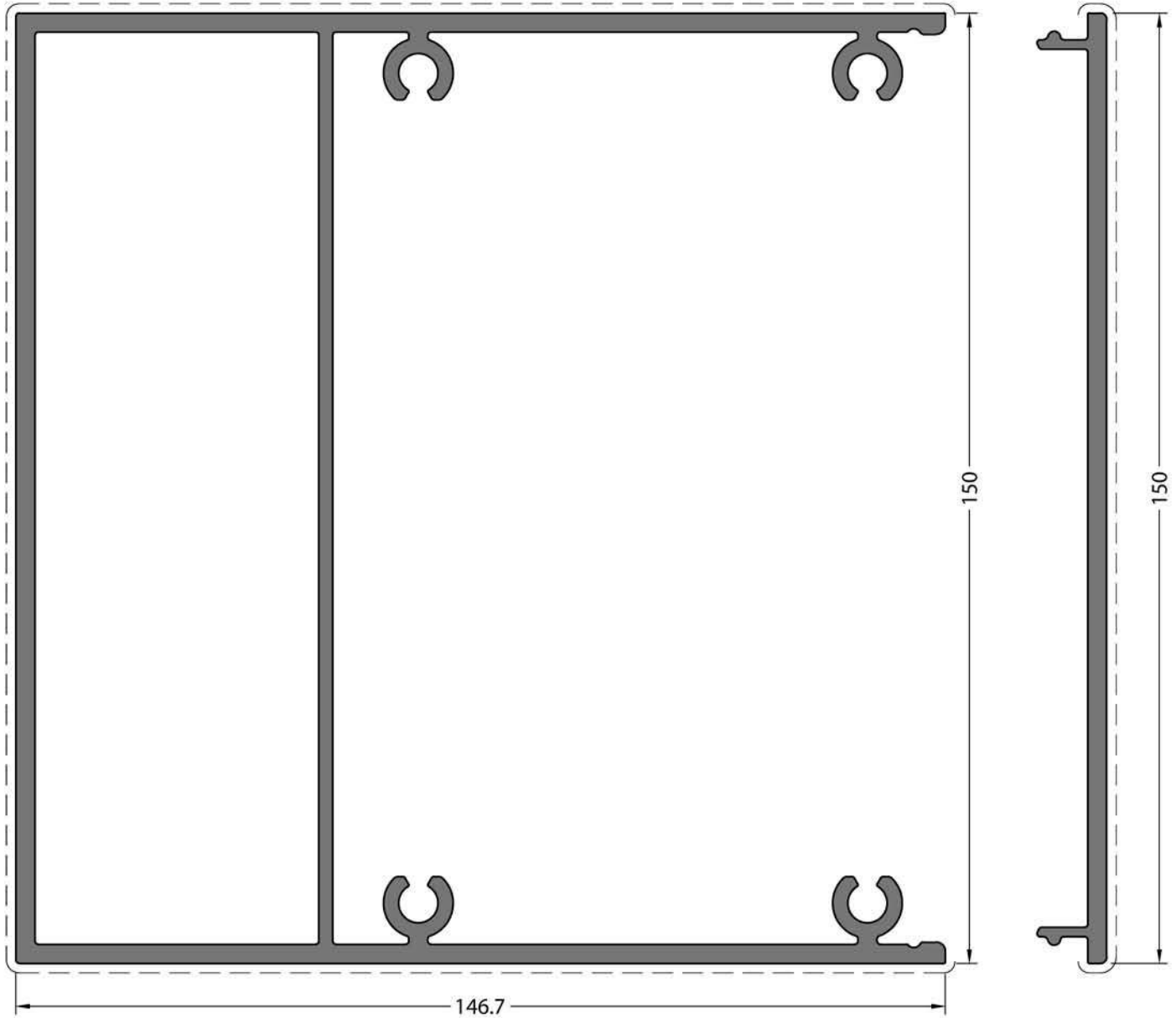

CODE / KOD

**150BC-101-00**

**THEORETICAL WEIGHT**  
TEORİK AĞIRLIK ( kg/m )

**5.108**

CODE / KOD

**150BC-102-00**

**THEORETICAL WEIGHT**  
TEORİK AĞIRLIK ( kg/m )

**1.291**

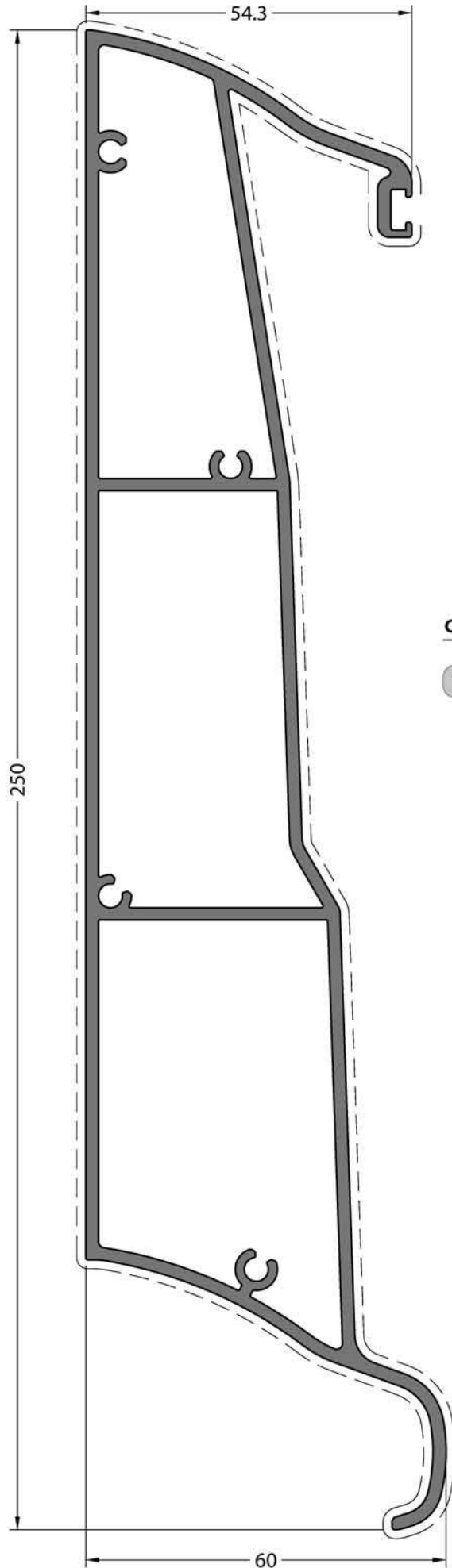

CODE / KOD

150BC-201-00

THEORETICAL WEIGHT

TEORİK AĞIRLIK (kg/m)

3.850

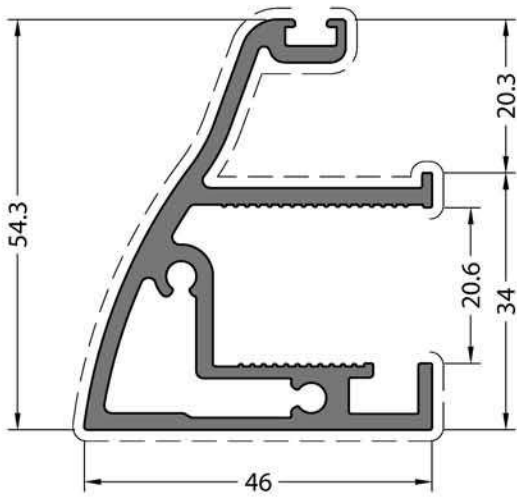

**CODE / KOD**  
**150BC-211-00**

**THEORETICAL WEIGHT**  
TEORİK AĞIRLIK ( kg/m )  
**1.247**

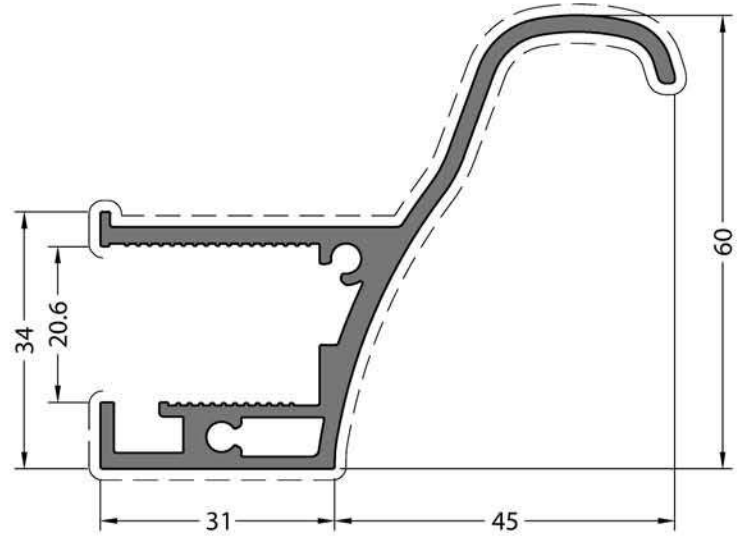

**CODE / KOD**  
**150BC-212-00**

**THEORETICAL WEIGHT**  
TEORİK AĞIRLIK ( kg/m )  
**1.233**

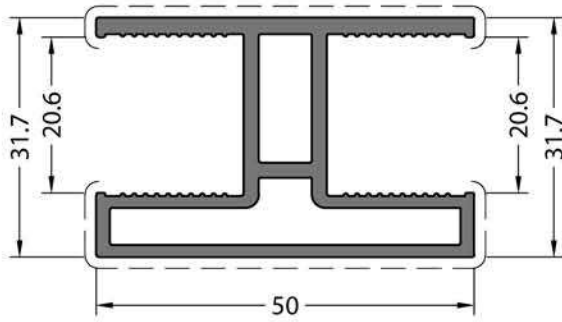

**CODE / KOD**  
**150BC-213-00**

**THEORETICAL WEIGHT**  
TEORİK AĞIRLIK ( kg/m )  
**1.032**

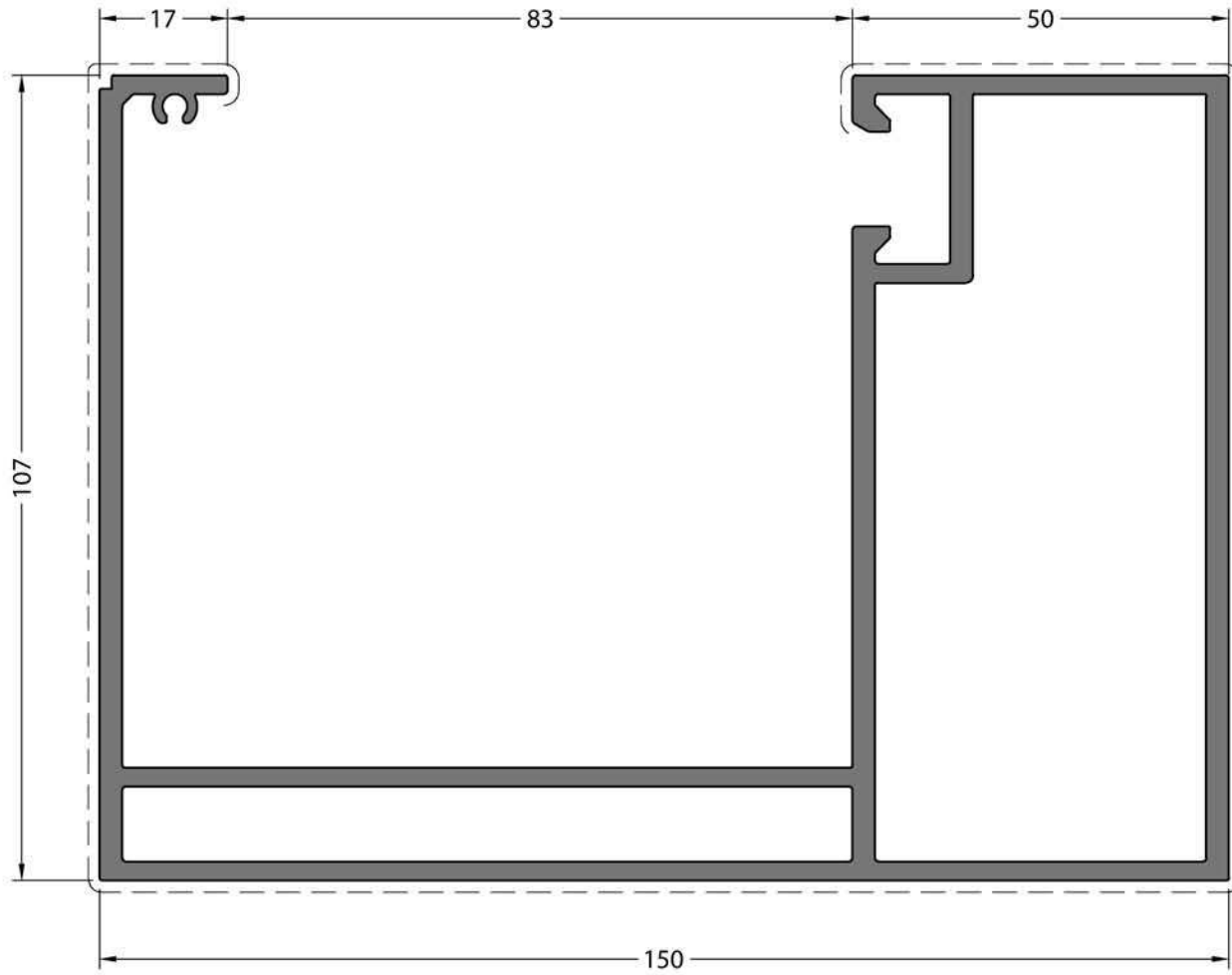

**CODE / KOD**

**150BC-301-00**

**THEORETICAL WEIGHT**

TEORİK AĞIRLIK (kg/m)

**4.815**



**CODE / KOD**

**150BC-302-00**

**THEORETICAL WEIGHT**

TEORİK AĞIRLIK (kg/m)

**1.299**

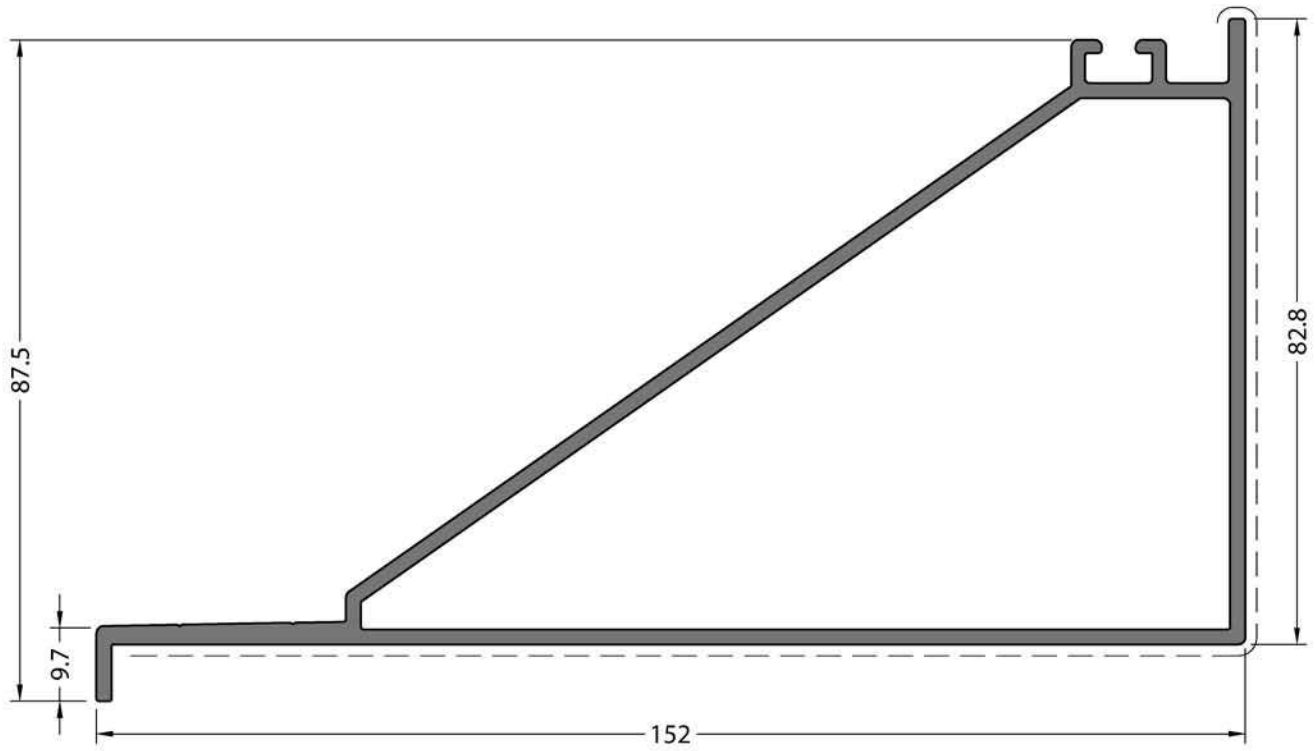

**CODE / KOD**

**150BC-303-00**

**THEORETICAL WEIGHT**

TEORİK AĞIRLIK ( kg/m )

**2.203**

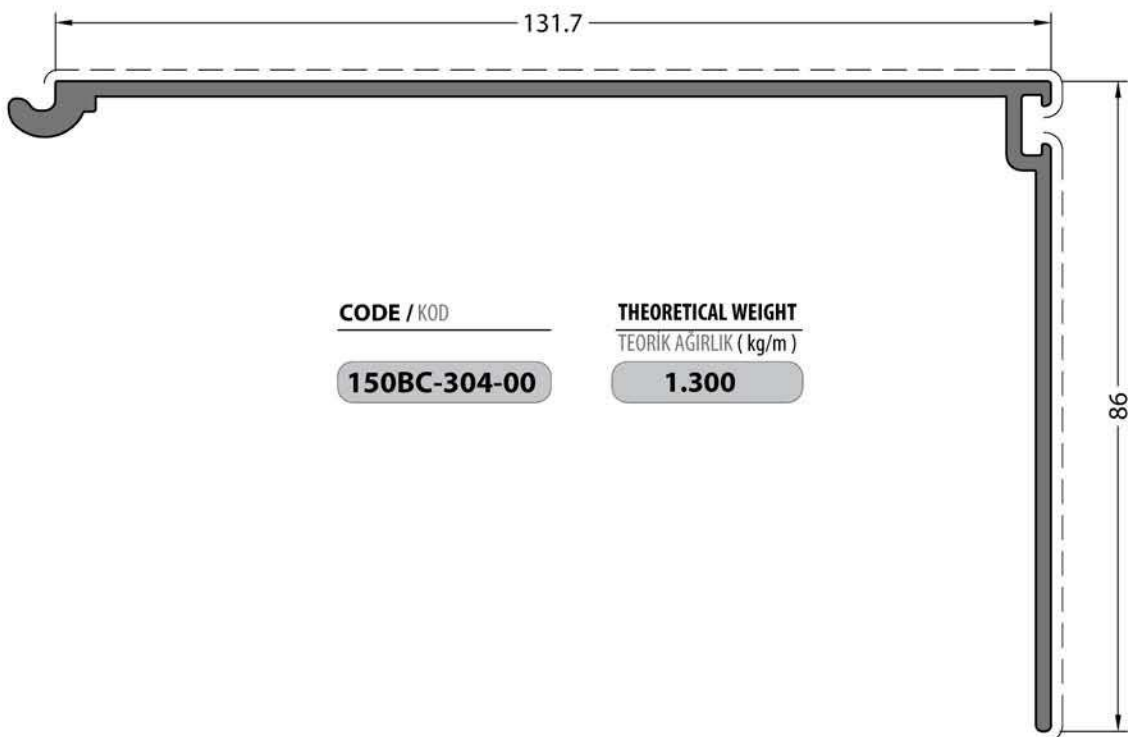

**CODE / KOD**

**150BC-304-00**

**THEORETICAL WEIGHT**

TEORİK AĞIRLIK ( kg/m )

**1.300**

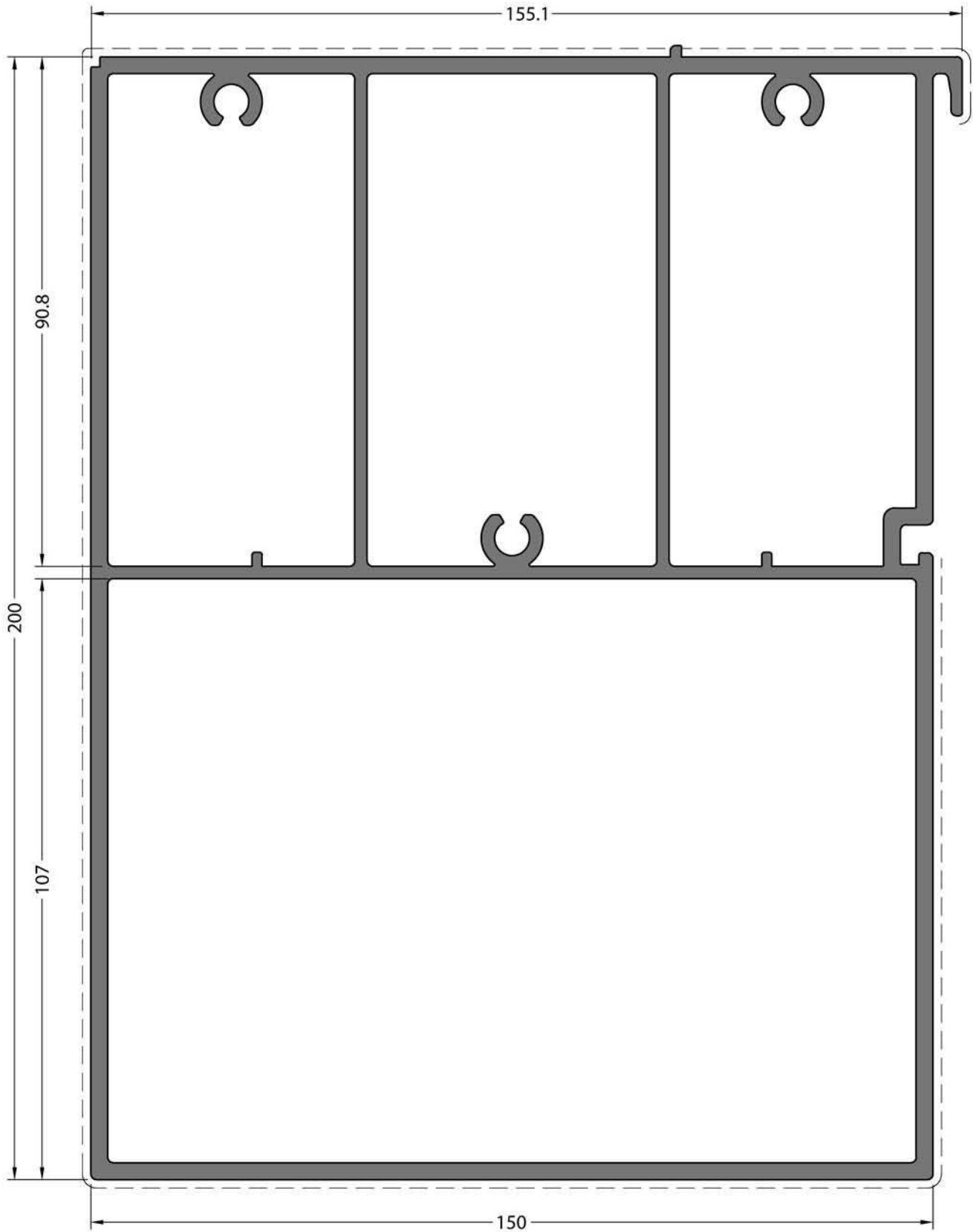

CODE / KOD

**150BC-401-00**

THEORETICAL WEIGHT

TEORİK AĞIRLIK (kg/m)

**8.080**

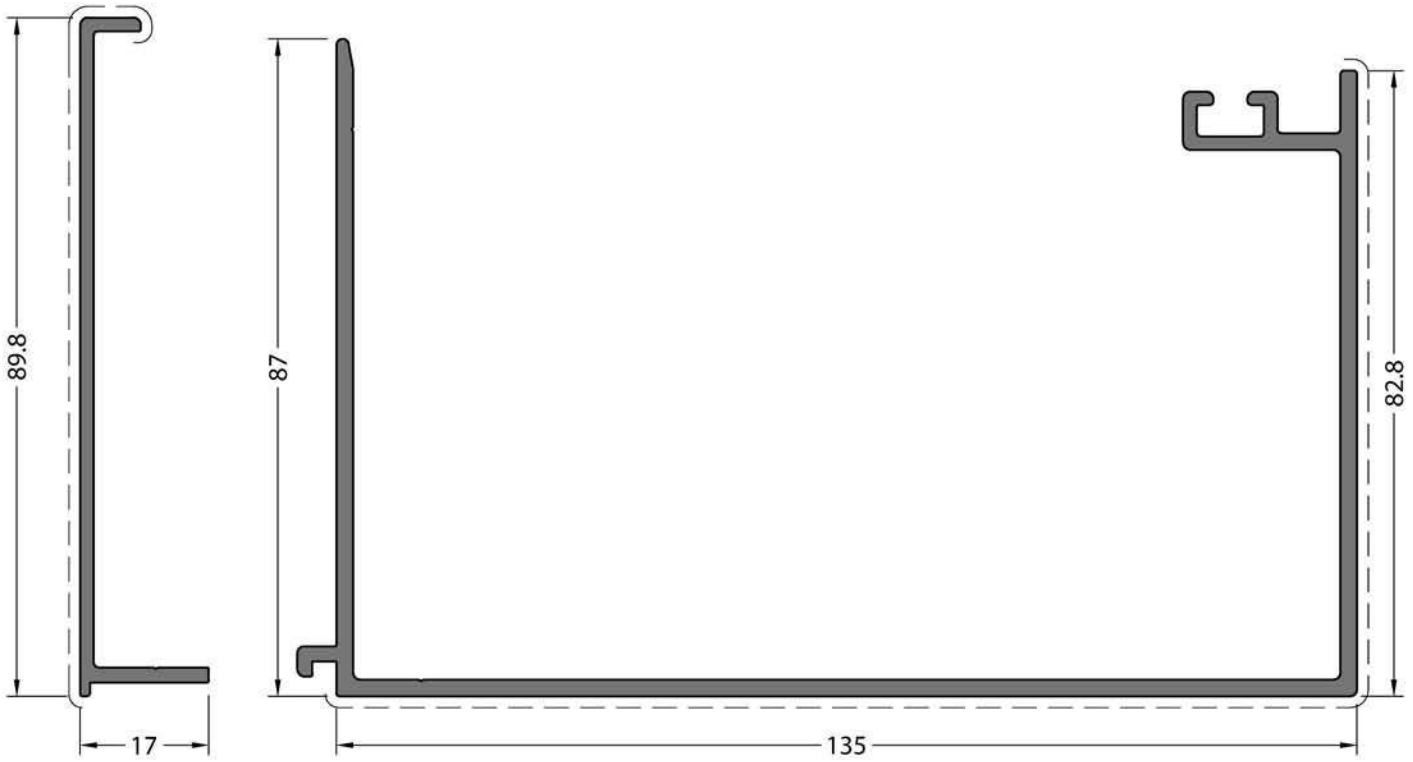

**CODE / KOD**

**150BC-402-00**

**THEORETICAL WEIGHT**  
TEORİK AĞIRLIK ( kg/m )

**1.291**

**CODE / KOD**

**150BC-403-00**

**THEORETICAL WEIGHT**  
TEORİK AĞIRLIK ( kg/m )

**2.004**

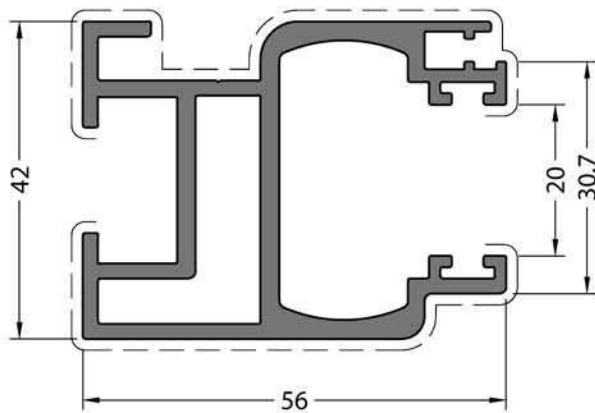

**CODE / KOD**

**150BC-501-00**

**THEORETICAL WEIGHT**  
TEORİK AĞIRLIK ( kg/m )

**1.507**

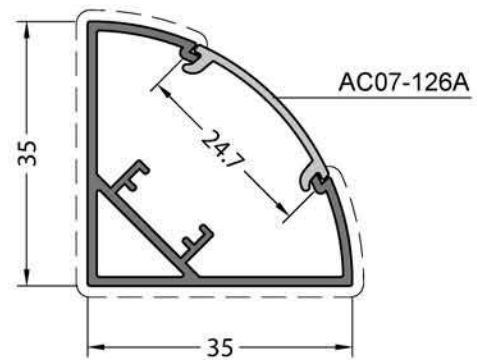

**CODE / KOD**

**07-126-00**

**THEORETICAL WEIGHT**  
TEORİK AĞIRLIK ( kg/m )

**0.419**

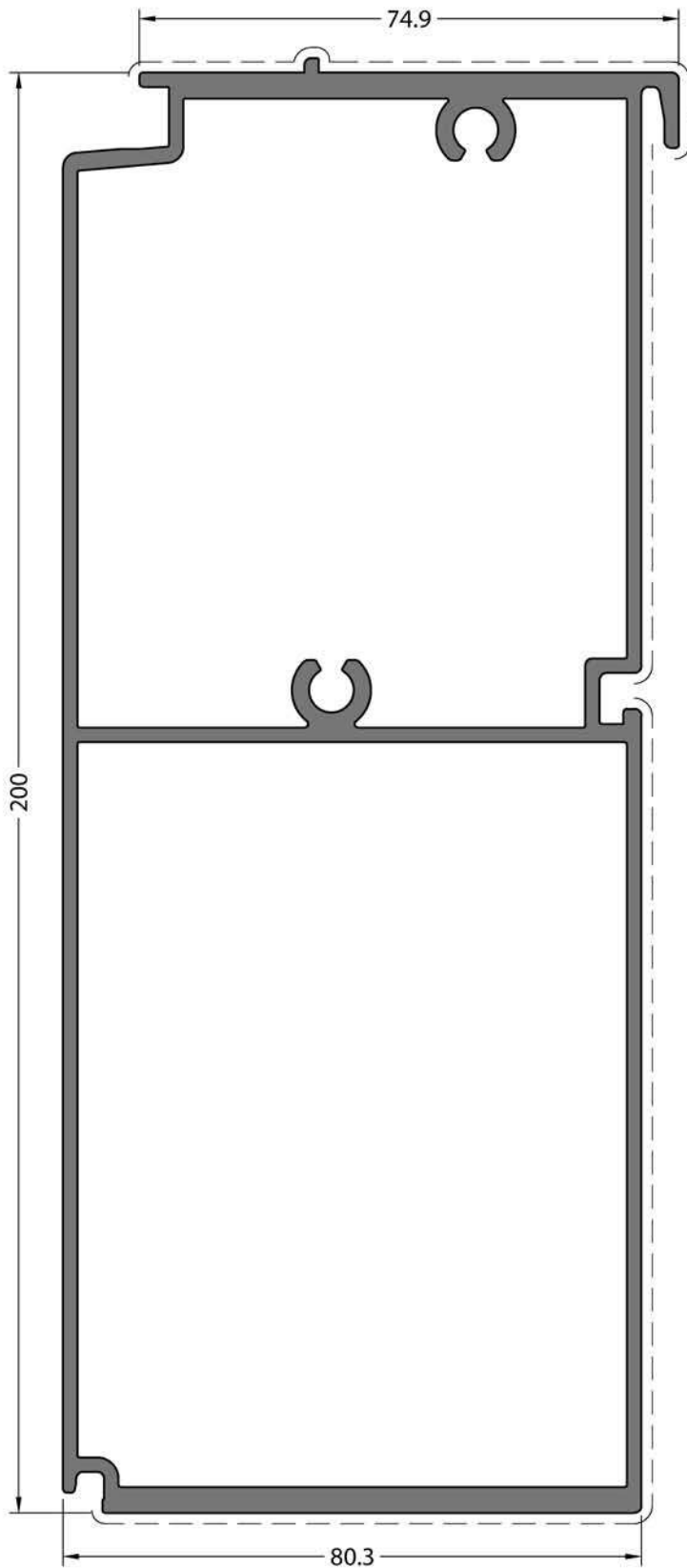

**CODE / KOD**

**150BC-411-00**

**THEORETICAL WEIGHT**  
TEORİK AĞIRLIK (kg/m)

**4.425**

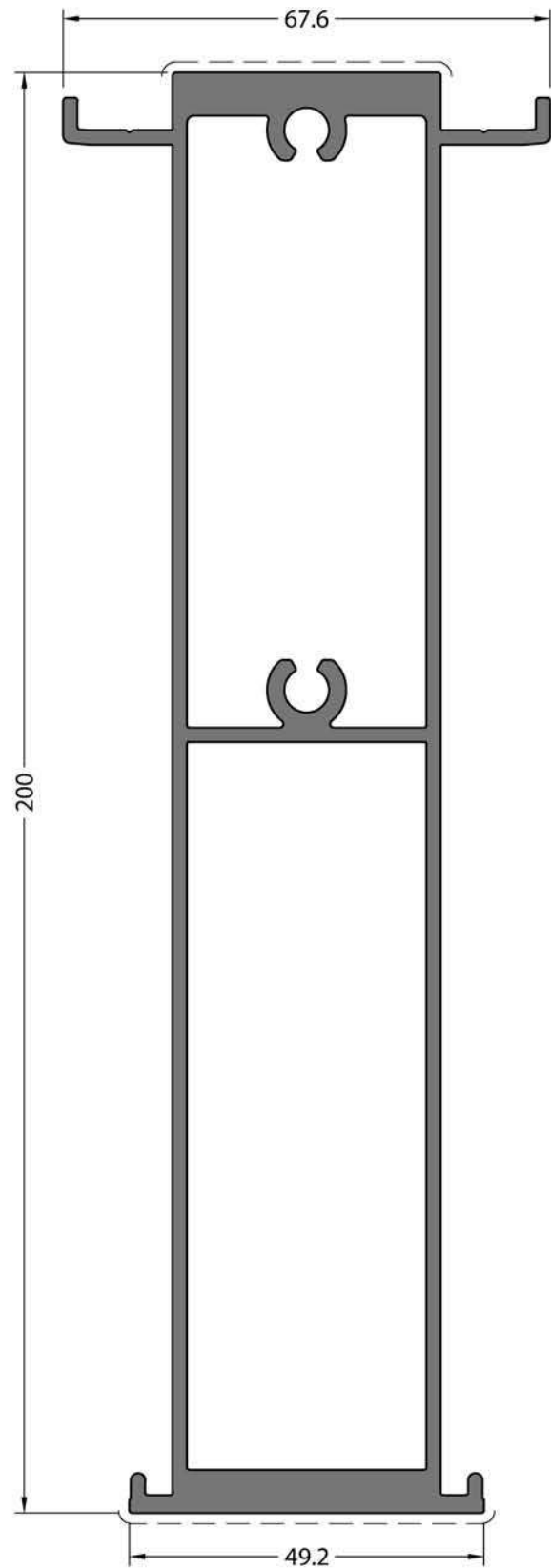

**CODE / KOD**

**150BC-413-00**

**THEORETICAL WEIGHT**  
TEORİK AĞIRLIK (kg/m)

**3.957**

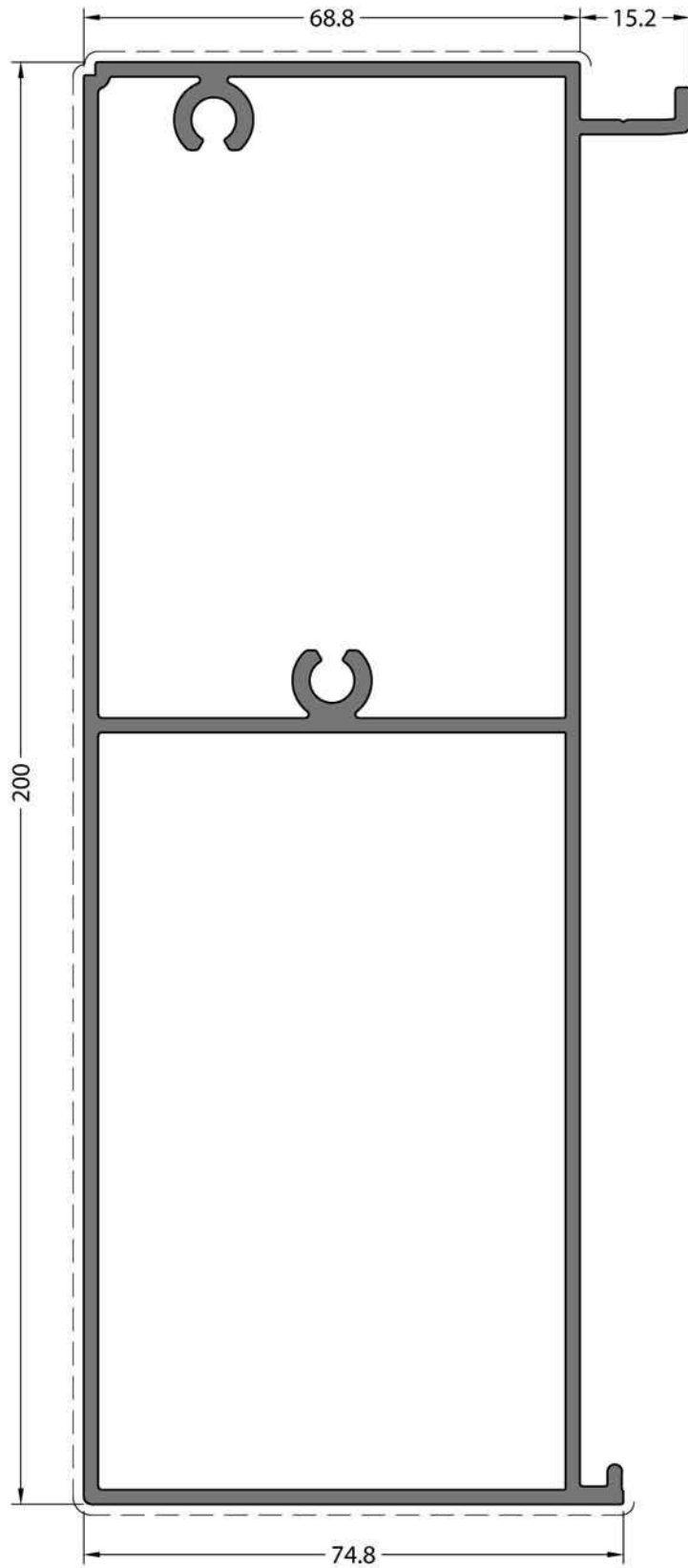

CODE / KOD

**150BC-412-00**

THEORETICAL WEIGHT  
TEORİK AĞIRLIK ( kg/m )

**3.666**

DETAILS  
DETAYLAR

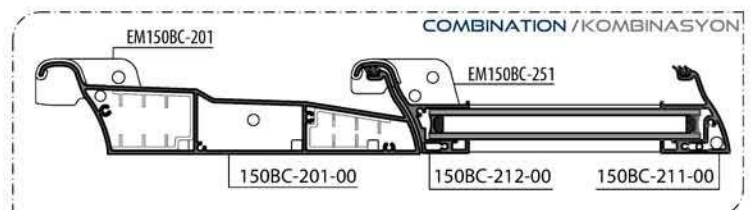
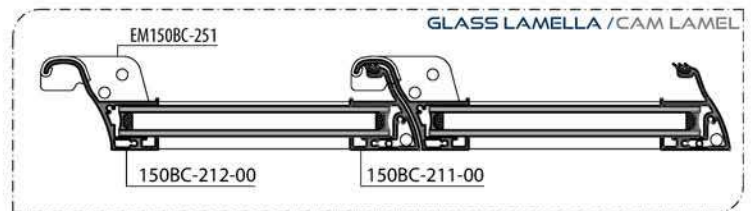
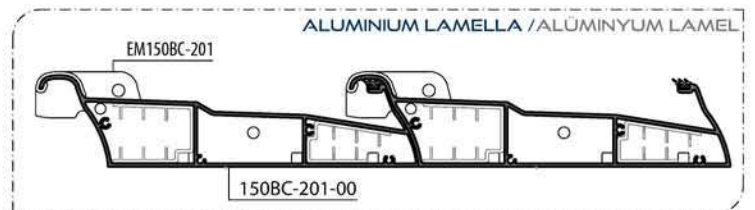
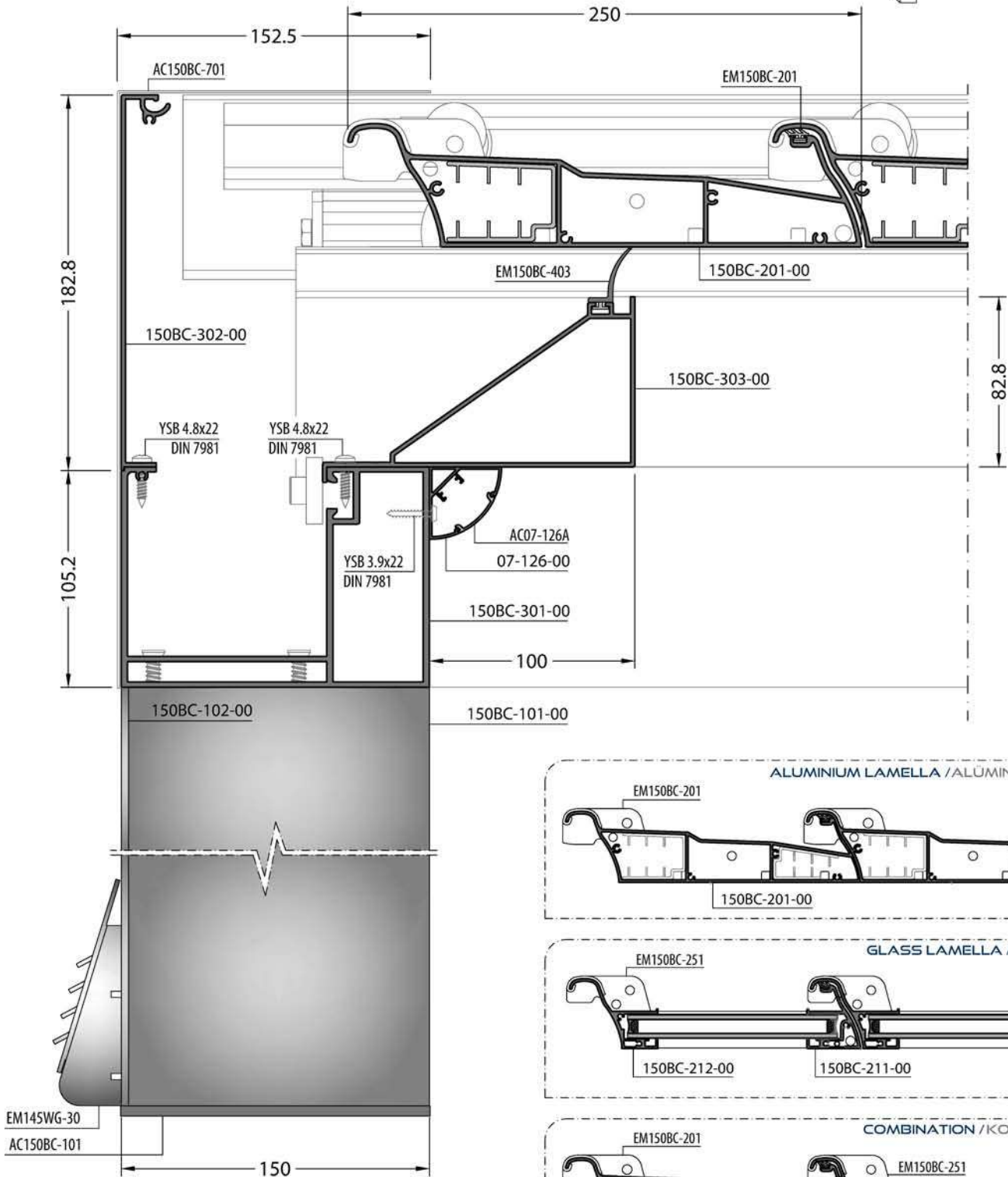
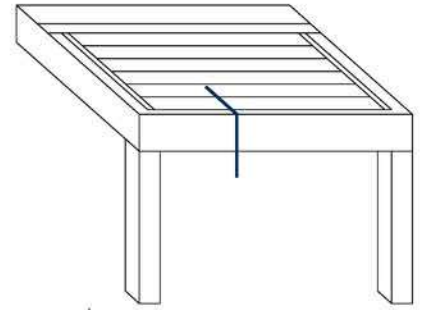

No scaled / Ölçeksiz

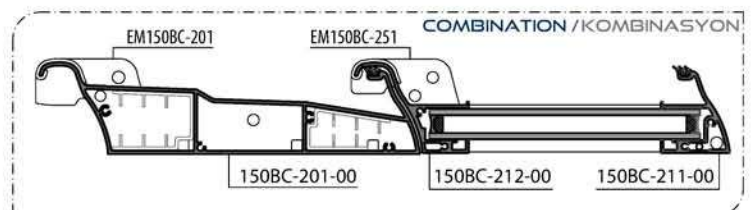
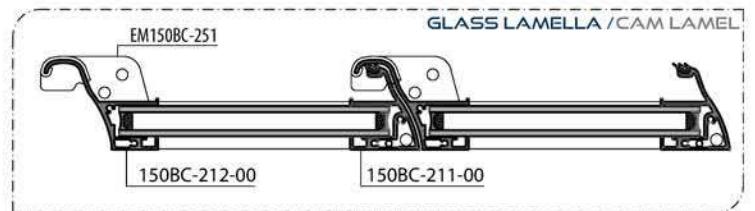
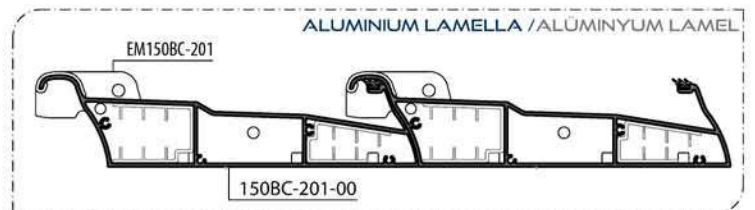
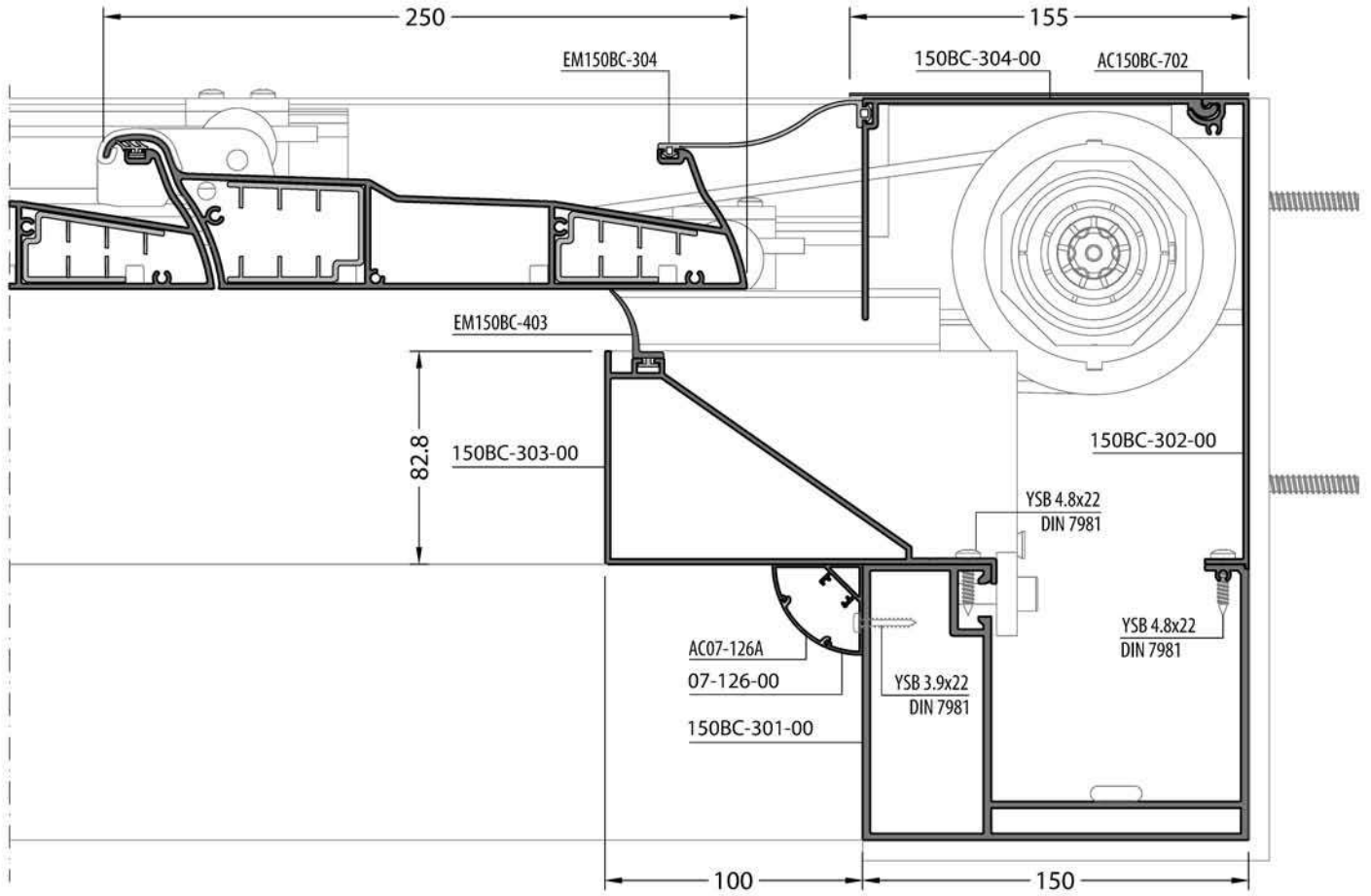
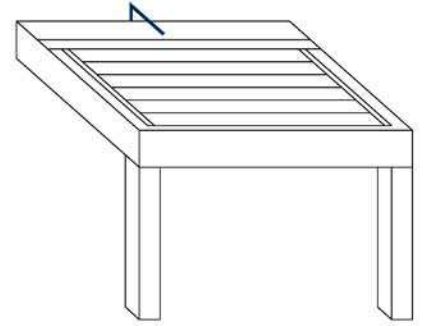

No scaled / Ölçeksiz

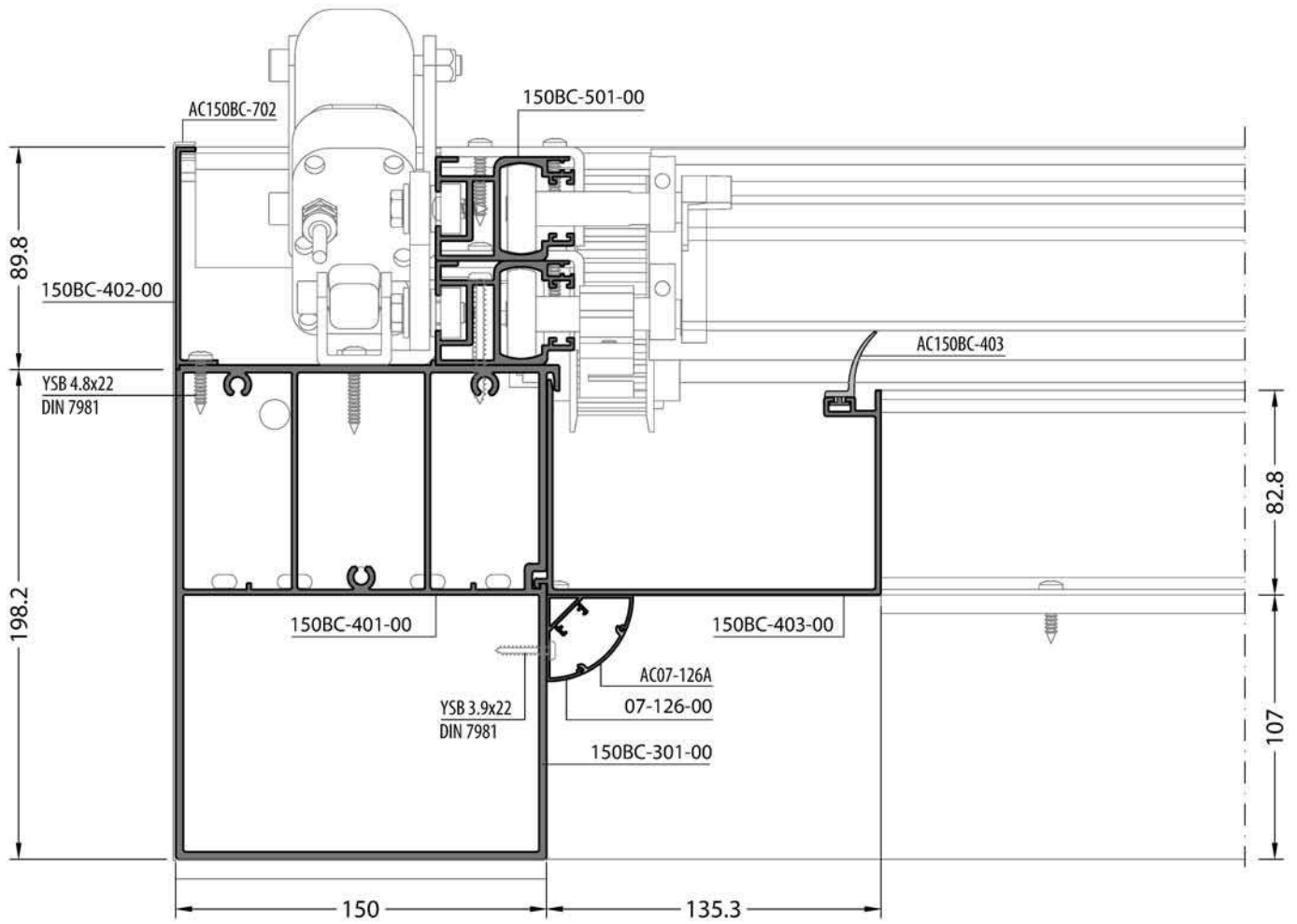
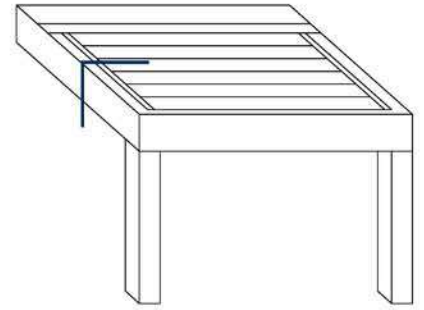

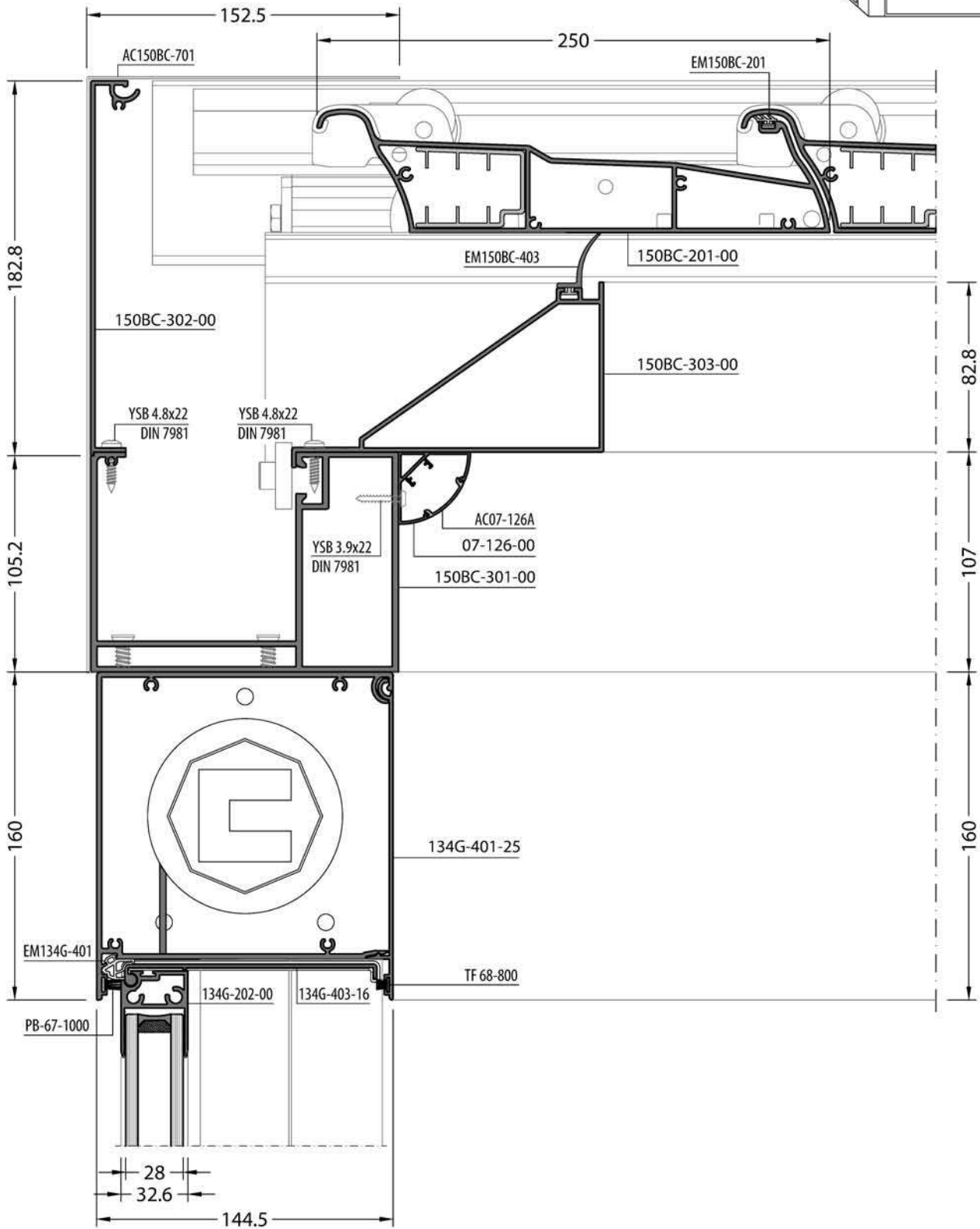
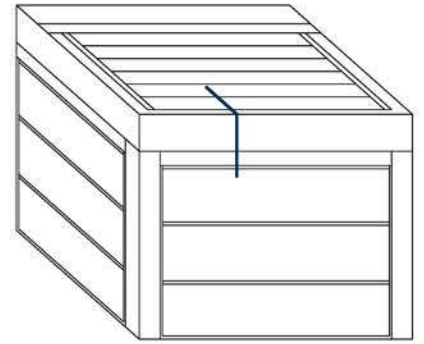

No scaled / Ölçeksiz

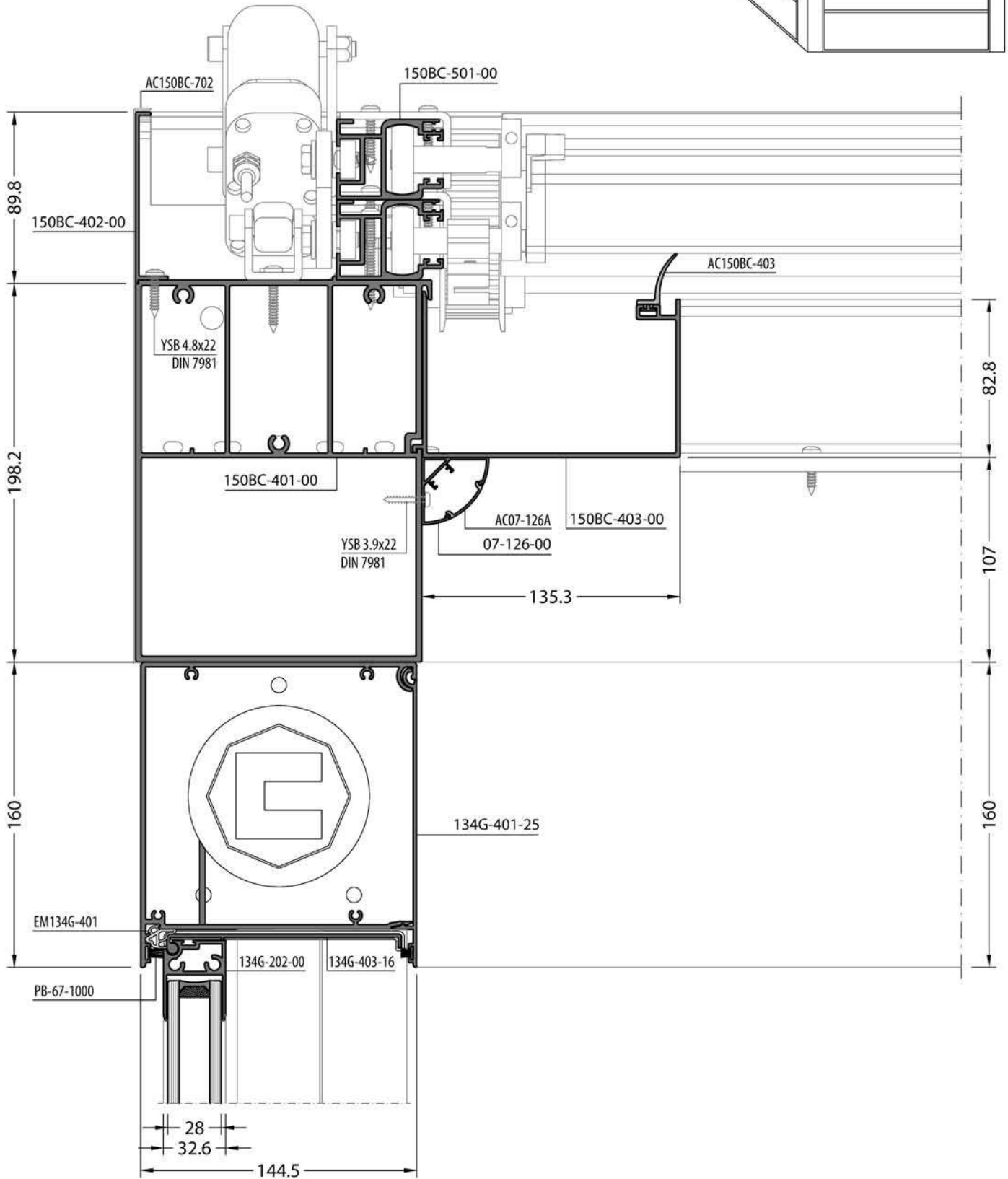
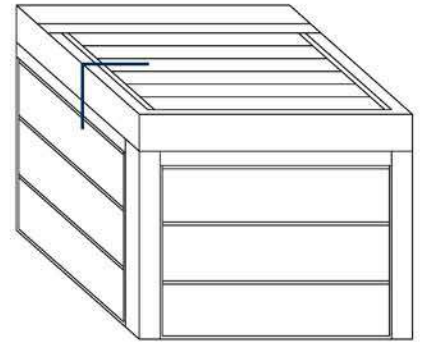

No scaled / Ölçeksiz

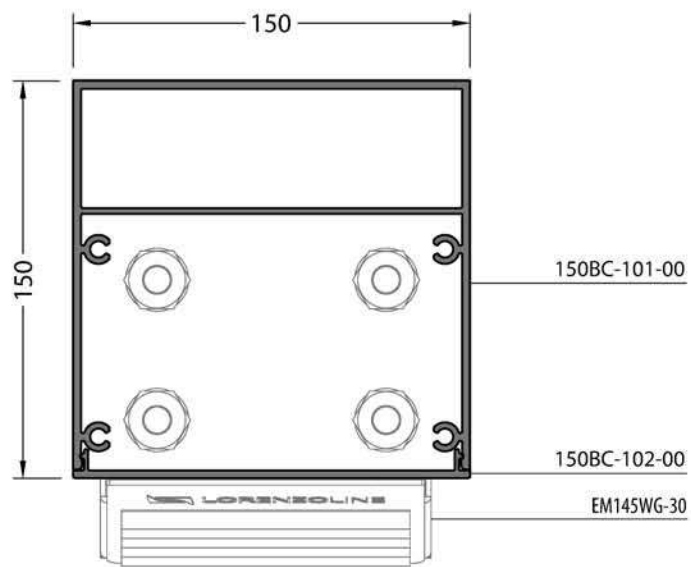
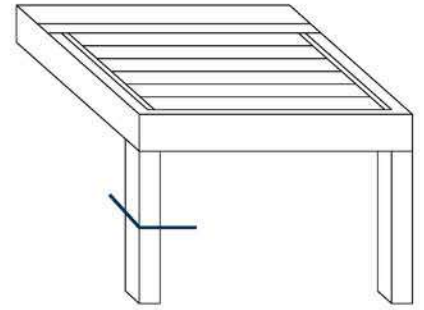

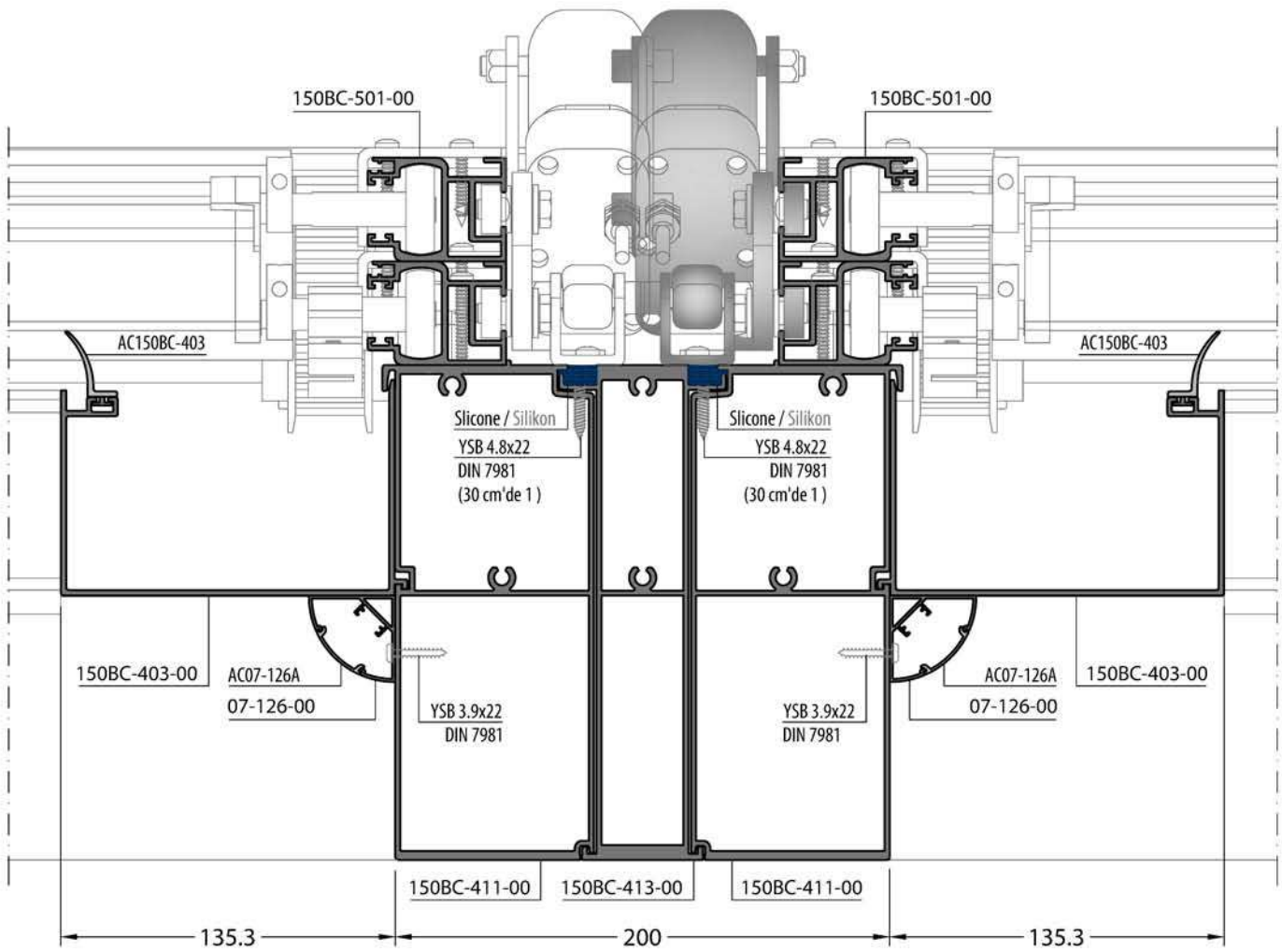
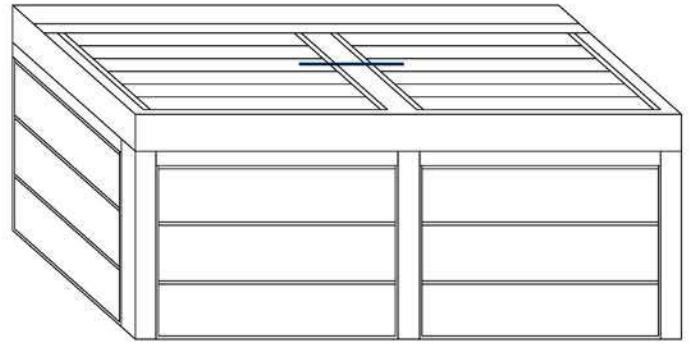

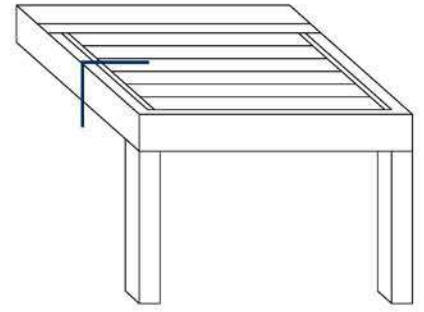

**150BC-401-00**  
**ALTERNATIVE PROFILE**  
**PROFİLİN ALTERNATİFİ**

